



Portable diesel fire pump with self-priming, single-stage, horizontal type centrifugal pump directly coupled to a diesel engine provides the opportunity to intervene in fires at the initial stage.

It has a flow rate of 10 m³/h and a pressure of 60 mwc and a 5 meter suction hose that works with electric power, wheeled with 20 meters of cloth fire hose, wolf mouth quick connect ends, water spray nozzle portable fire pump is offered as a complete package. Foam ejection on request with the addition of a mixer and foam nozzle, it can throw both water and foam.

DIESEL PUMP SPECIFICATIONS

Body	Cast Iron
Fan	Aluminum
Seal	Mechanical
Inlet - Outlet Diameter	2"
Pump Capacity	10 m ³ /h - 6 Bar

DIESEL MOTOR SPECIFICATIONS

10 HP, 3600 rpm, air cooled engine
4 cycle, single cylinder, diesel engine
Manual operation
Electrical start/stop
12Vdc battery
Voltaj : 220-230V - 50Hz
Oil pressure safety
Fuel Tank: 5 L
Fuel Consumption: 1,8 lt/h

DIMENSIONS

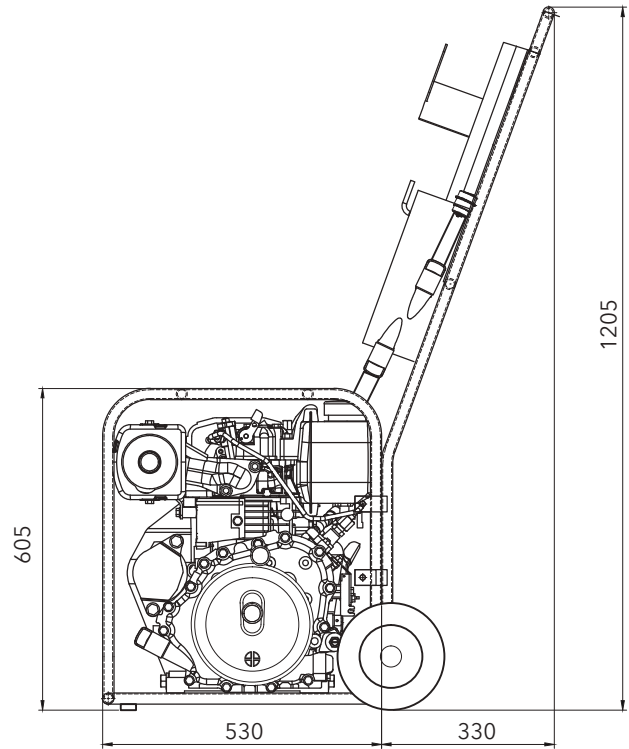
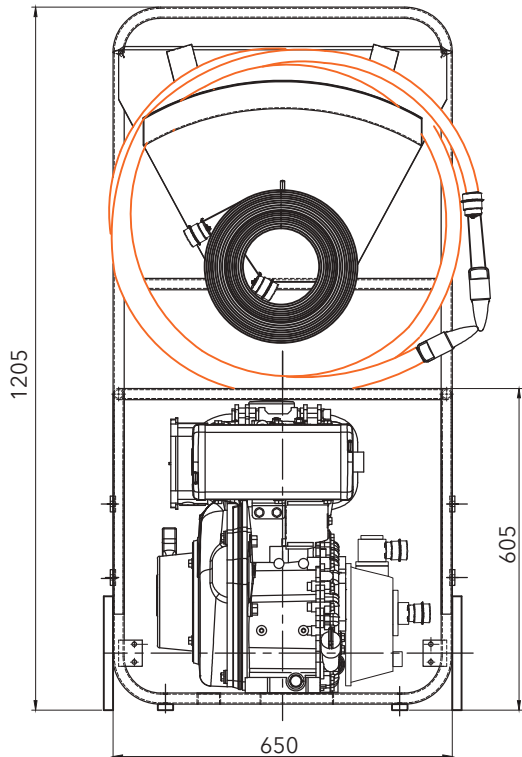

Weight: 145 kg