

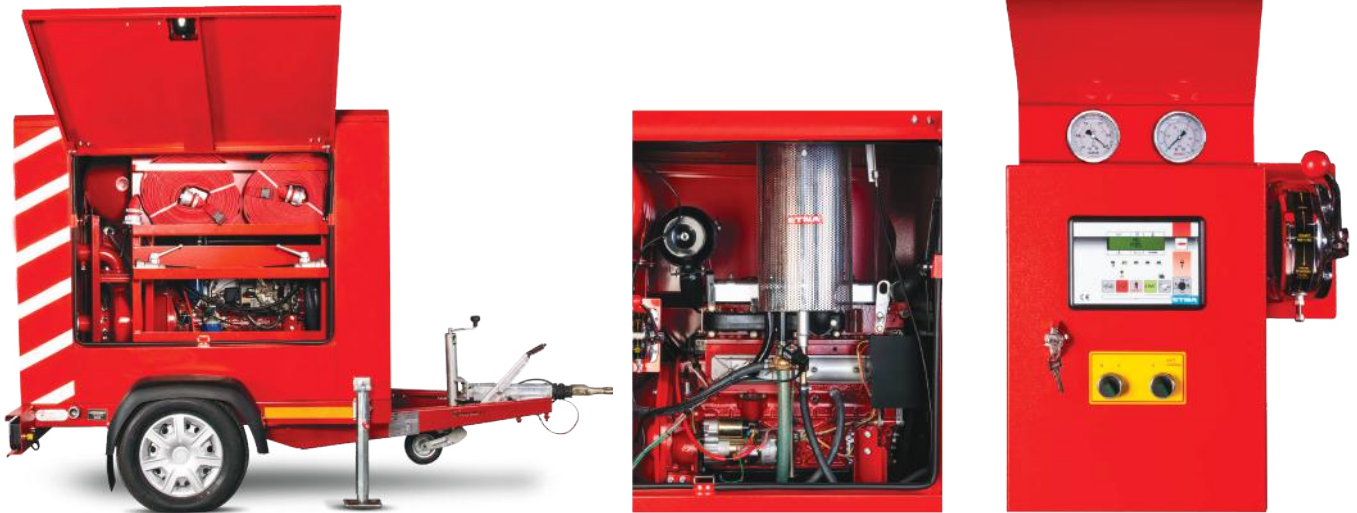

**Mobile Fire Extinguishing and Flood
Drainage Pump
HIZIR & HIZIR LIFT**



Mobile Fire Extinguishing and Flood Drainage Pump HIZIR & HIZIR LIFT



There are two versions of HIZIR, a high performance pump connected directly to the diesel engine with an flexible coupling. While HIZIR is mounted on a trailer, HIZIR LIFT can be mounted on a fixed platform or transported in a movable vehicle body (truck, pickup truck). Thanks to the exhaust gas priming system, without filling the suction hose, priming the water to the pump is very easy and quick (approx. 40 sec.).

Suction house, discharge house, water spraying lance, on request foam mixer can be added to spray foam (optional), fuel tank, control and startup panel, battery are included all equipment are mounted on two wheel trailer ready to operate.

Municipalities, factories, marinas, military bases, fuel storage facilities, disaster fighting organizations, places where there is no fire pump station or flood emptying facilities, this unit can be used very fast and easily. The unit can be pulled by a water tanker or behind any vehicle for fire-fighting or dewatering purposes.

	HIZIR 90/41
Flow	90 m ³ /h
Pressure	90 mSS
Type	50/268 Norm Pump
Suction Diameter	DN 65 mm (Flanged)
Discharge Diameter	DN 50 mm (Flanged)
Seal	Mechanical
Body	GG 25 Cast Iron
Impeller	268 mm Bronze
Fuel Tank	50 L
Fuel Consumption	11,2 L/h
Weight	1200 kg

Diesel Engine: 42 kW - 2900 rpm, four-stroke, water cooled, starter motor, four cylinders (ETNA OEM brand)

	HIZIR 120/65
Flow	120 m ³ /h
Pressure	90 mSS
Type	65/268 Norm Pump
Suction Diameter	DN 80 mm (Flanged)
Discharge Diameter	DN 65 mm (Flanged)
Seal	Mechanical
Body	GG 25 Cast Iron
Impeller	268 mm Bronze
Fuel Tank	50 L
Fuel Consumption	17,5 L/h
Weight	1200 kg

Diesel Engine: 65 kW - 2900 rpm, four-stroke, water cooled, starter motor, four cylinders (ETNA OEM brand)

Trailer

Two wheel trailer can cruise on high-way (permission is optional) pulling connection, with brake.

Start and Control Panel

To operate the diesel engine there is a control panel, on the panel; oil pressure gauge, water temperature gauge, fuel indicator, engine speed gauge, engine start key, speed adjusting arm.

Accessories

Two pieces 2" suction hose 3 m. two pieces 2" discharge hose 20 m., quick coupling connection locks, water spray lance, suction side of the pump two way 2" suction cam locks, discharge side two way 2" valve control discharge cam locks, foam substance tank.



Suction Hose 3 meters Discharge Hose 20 meters

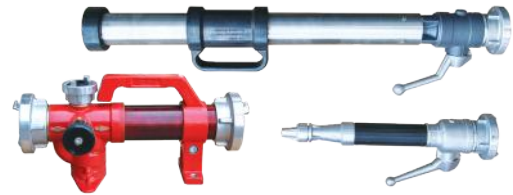

Foam Mixer

Running The Unit

The unit can be used for fire-fighting and flood drainage purpose. In both cases the trailer should be pulled by a vehicle to the place where it will be used. By the help of quick coupling at the both end of suction and discharge hoses, can be connected to the suction and discharge end of the pump. The suction hose can be immersed to a pool, lake or a water reservoir or can be connected to a water tanker. The diesel engine starts by starter motor, to develop a vacuum at the suction side of the pump to prime water by closing the exhaust arm, exhaust gas passes through a venturi, after 30 or 40 seconds water is primed into the

pump and pump is ready to operate. After priming of the water the exhaust arm is opened and the water comes from the spraying lance. On request a foam mixer can be used to spray foam on inflammable substances. In case the unit will be used flood drainage the suction hose should be immersed to the place to drain and same process is used to run the pump fast and easy. Pump is not suitable to drain sewage. Pump can drain flood water or dirty water having not different size of particles.

Note: The unit can't be used for irrigation by sucking water from a river or a lake.

HIZIR Dimensions

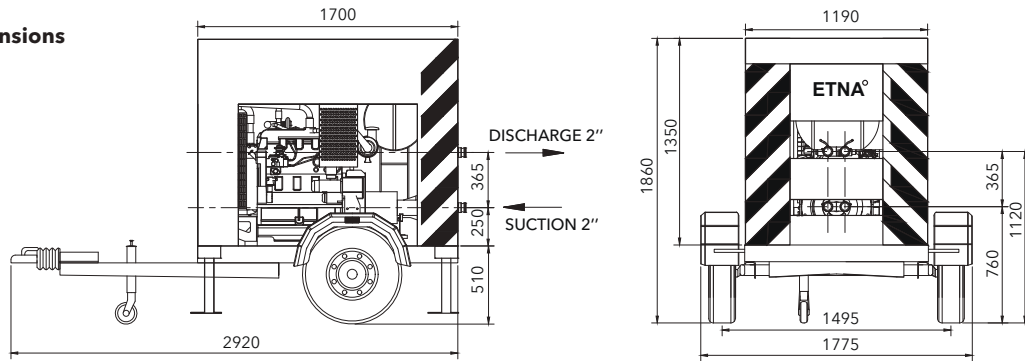

HIZIR LIFT Dimensions

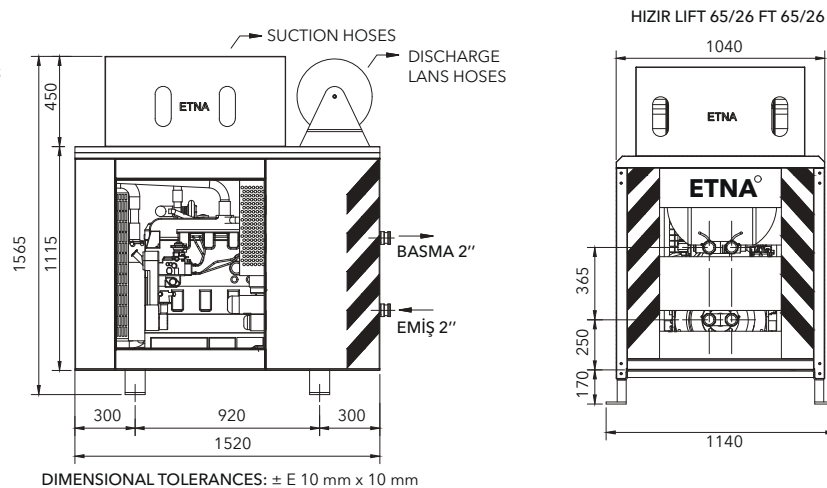



Dudullu Organize Sanayi Bölgesi 2. Cadde No: 14
34775 Ümraniye - İstanbul / Turkey
Tel : +90 216 561 47 74 (Pbx) • Fax : +90 216 561 47 50
www.etna.com.tr/en • info@etna.com.tr



ETNA®

0850 455 38 62
customer service