

ETNA®

Smart Circulators Suitable for Use in HVAC Systems



Smart Circulators Suitable for Use in HVAC Systems ECP-F Series



The **ECP-F series** is an efficient, electronic, smart circulation pump equipped with a permanent magnet motor and a smart pressure control system. The rotating parts are immersed in the pumped liquid, which cools the motor and lubricates the bearings. The product does not leak, operates extremely quietly, saves energy and ensures high efficiency.

- High accuracy algorithm
- THD (Total Harmonic Distortion) 8%
- Power factor > 98%
- Power detection accuracy $\pm 3\%$



**Commercial
Air Conditioning**



**Commercial
Heating**



**Domestic
Heating**

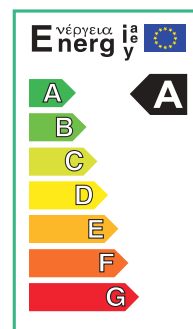

EEI ≤ 0.23

Naming Details

ECP 50 - 120 F 280 N

- Pump casing material: stainless steel
- Distance between suction and discharge (mm)
- Flanged connection
- Max. discharge height (dm)
- Suction/discharge size (mm)
- Product model

Technical Specifications

Maximum Power	: up to 1523 W
Maximum Flow Rate	: 68 m ³ /h
Maximum Discharge Height	: 18 m
System Pressure	: 10 Bar
Fluid Temperature	: up to +110°C

6 MAIN ADVANTAGES



3 Operation Modes



Class A Energy Efficiency



Non-leakage



Permanent Magnet Motor



Low Noise Operation



Easy Installation

Pump Configuration

Motor	: High efficiency permanent magnet motor
Pump shaft	: Tungsten carbide sprayed stainless steel
Bearing	: Ceramic
Thrust bearing	: Graphite carbon
Impeller	: High temperature resistant composite material

Pump Properties

- Class A energy efficiency, EEL 0.23;
- Permanent magnet motor with smart frequency control;
- Proportional pressure mode;
- Constant pressure mode;
- Constant speed mode;
- Low noise;
- No leakage.

Uygulama Limitleri

- Installed in heating circulation system;
- Operating Conditions
Ambient temperature: 0~40°C;
Ambient humidity: <95%;
Fluid temperature: -10 °C ~ +110 °C;
- The ambient temperature is lower than the fluid temperature to prevent condensation inside the motor;
- Fluid material: Non-corrosive, non-explosive liquid; free of solid particles, fibers and mineral oil;
- Usage requirements: Do not operate dry for more than 10 seconds.



Pump Component Detail



Shaft

AISI304 Stainless Steel

Tungsten carbide sprayed on the shaft surface enables 5-fold increase in wear resistance.

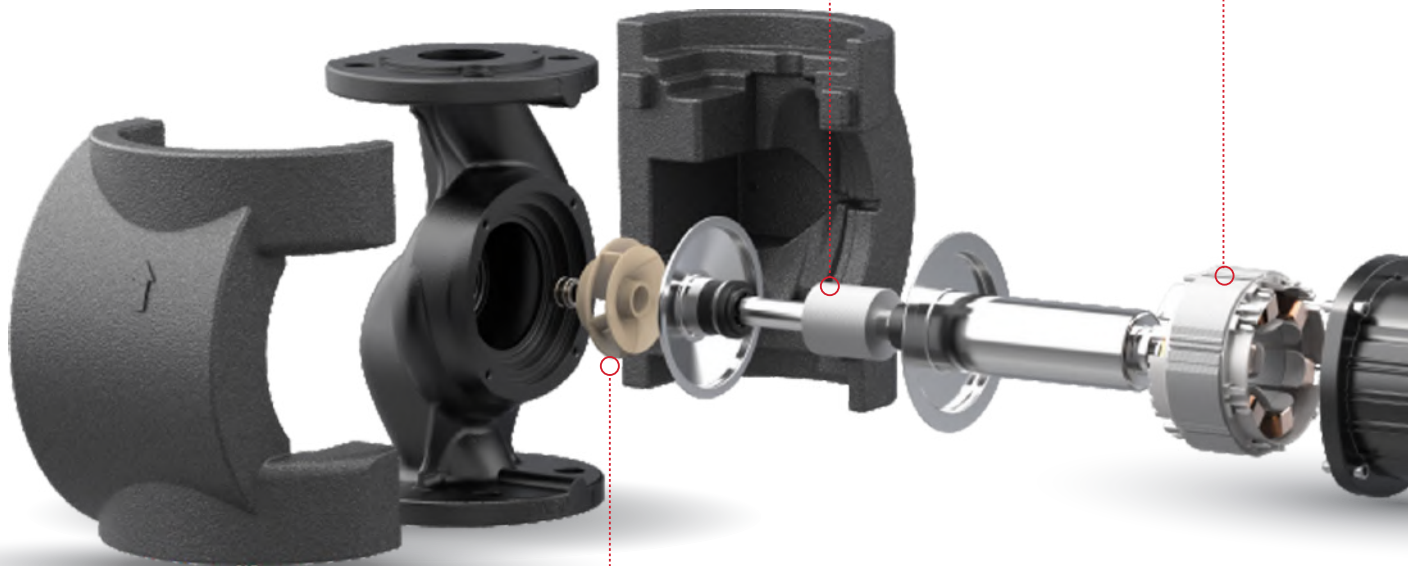

Impeller (fan)

High Temperature Resistant Composite Material

Hydraulic efficiency is maximized with improved hydraulic design.



**Impeller with
High Temperature
Resistant Composite
Material**



**Permanent
Magnet Motor**



**Stainless Steel
Rotor Shaft**

Product Advantages

- + High temperature resistant composite impeller
- + Tungsten carbide sprayed stainless rotor shaft
- + High power permanent magnet synchronous motor

Motor

Permanent Magnet Motor

High power permanent magnet synchronous motor in 15-1523 Watt range



Technical Specifications

Model	Nominal voltage (V)	Power frequency	Input power	Max. Current	Max. Flow rate (m ³ /h)	Max. discharge height (m)	Max. Pressure	Distance Between Flanges (mm)
ECP 32-120F 220(N)	1 x 230 V	50 / 60 Hz	15 .. 329 W	0.17 .. 1.48 A	11	12	PN6/10	220
ECP 40-120F 250(N)	1 x 230 V	50 / 60 Hz	15 .. 463 W	0.18 .. 2.05 A	24	12	PN6/10	250
ECP 40-150F 250(N)	1 x 230 V	50 / 60 Hz	16 .. 615 W	0.18 .. 2.71 A	26.2	15	PN6/10	250
ECP 50-80F 240(N)	1 x 230 V	50 / 60 Hz	21 .. 331 W	0,22 .. 1,48 A	27	8	PN6/10	240
ECP 50-120F 280(N)	1 x 230 V	50 / 60 Hz	20 .. 533 W	0.22 .. 2.37 A	33	12	PN6/10	280
ECP 50-180F 280(N)	1 x 230 V	50 / 60 Hz	22 .. 769 W	0.24 .. 3.4 A	37.5	18	PN6/10	280
ECP 65-100F 340(N)	1 x 230 V	50 / 60 Hz	25 .. 619 W	0,26 .. 2,73 A	44	10	PN6/10	340
ECP 65-150F 340(N)	1 x 230 V	50 / 60 Hz	31 .. 1263 W	0.31 .. 5.53 A	56	15	PN6/10	340
ECP 80-120F 360	1 x 230 V	50 / 60 Hz	31 .. 1277 W	0,28 .. 3,16 A	60	12	PN6	360

Interface: Modbus RTU (RS-485)

Smart Circulators Suitable for Use in Small Residential Heating Systems ECP 32-12-180 Series

ECP 32-12-180 series pumps are used in single, double pipe systems or heating water circulation systems. It has advantages such as optional PWM control, high comfort, low noise, low energy consumption.

* Interface: PWM controlled

* N - Pump casing material: stainless steel

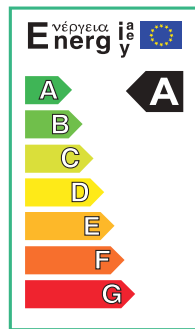

EEI ≤ 0.23

Naming Details

ECP 32 - 12 180 N

- Pump casing material: stainless steel
- Distance between suction and discharge
- Max. discharge height (m)
- Suction/discharge size (mm)
- Product model

Technical Specifications

Maximum Power	: Up to 220 W
Maksimum Debi	: 10,5 m ³ /sa
Maksimum Basma Yüksekliği	: 12 m
Sistem Basıncı	: 10 Bar
Fluid Temperature	: Maximum +110°C

Precise Power Utilization, Multiple Protection



**Memory with
Restart**



**Fault
Detection**



**Slider
Design**



**Overheating
Protection**



**Over Current
Protection**

Pump Configuration

Motor	: High efficiency permanent magnet motor;
Pump shaft	: Ceramic shaft;
Bearing	: Ceramic;
Thrust bearing	: Graphite carbon;
Impeller	: High temperature resistant composite material

GT: In the absence of a PWM signal, the pump operates at the maximum constant speed curve.

ST: If there is no PWM signal, the pump stops.

Pump Properties

- Class A energy efficiency, $EEL < 0.23$;
- Permanent magnet motor with smart frequency control;
- Proportional pressure mode;
- Constant pressure mode;
- Constant speed mode;
- Low noise;
- No leakage.

Application Limits

- Installed in heating circulation system;
- Operating Conditions
 - Ambient temperature: $0 \sim 40^{\circ}\text{C}$;
 - Ambient humidity: $< 95\%$;
 - Fluid temperature: $-10^{\circ}\text{C} \sim +110^{\circ}\text{C}$;
- The ambient temperature is lower than the fluid temperature to prevent condensation inside the motor;
- Fluid material: Non-corrosive, non-explosive liquid; free of solid particles, fibers and mineral oil;
- Usage requirements: Do not operate dry for more than 10 seconds.

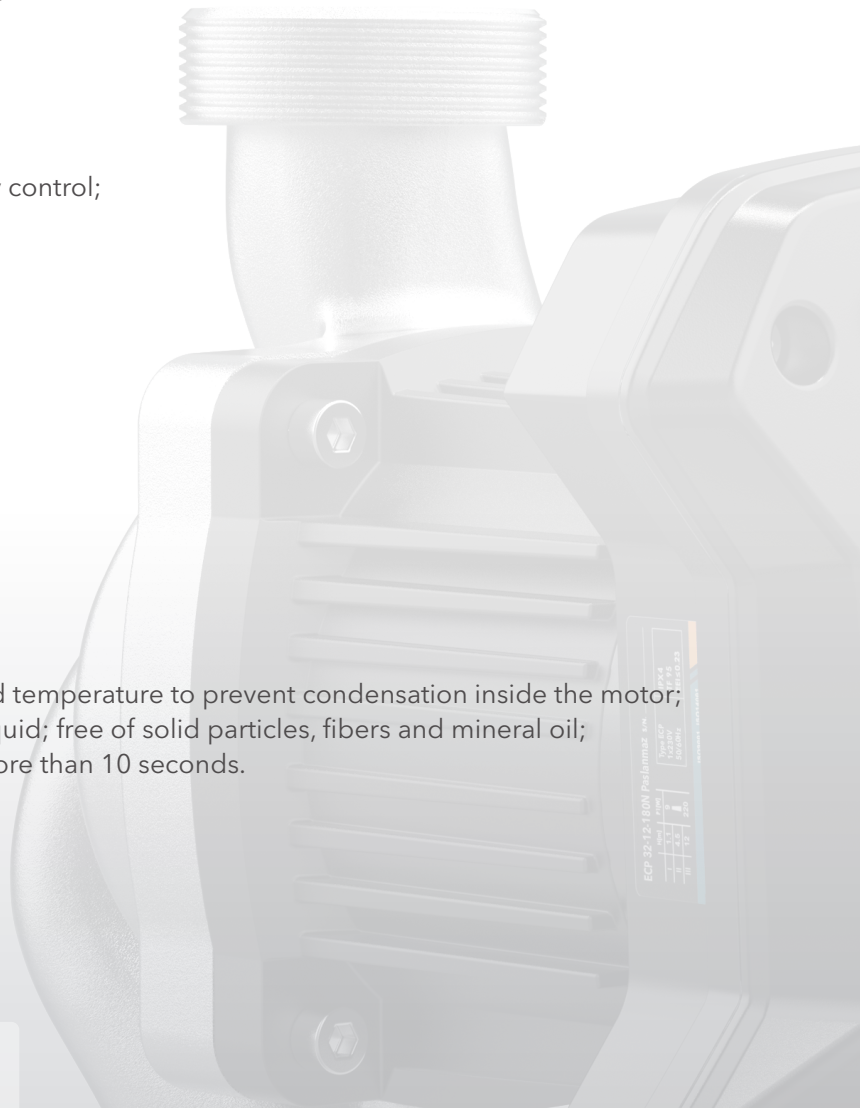

**WE ALWAYS SUPPORT YOU ACROSS TURKEY
WITH MORE THAN 100 FAST AND RELIABLE
SERVICE POINTS AFFILIATED WITH OUR
HQ SERVICE CENTER!**



After-Sales Services

- Installation Supervision • Equipment Commissioning
- Troubleshooting • Spare Parts Supply

