

Residential Fire-Fighting Booster Systems

! Residential fire fighting booster systems are only suitable for use in low and medium hazard class buildings with **"fire cabinets"**.

Residential Water Boosters With Alarm Kits

Y-KO Series

Applicable for fire-fighting systems of residential buildings such as houses and blocks of apartments etc.

Pump Properties

Pump Casing	: AISI304 Stainless Steel
Fan & Diffuser	: Noryl
Pump Shaft	: AISI420 Stainless Steel
Suction - Discharge Body	: GG25 Cast Iron
Mechanical Seal	: Carbon / Ceramic / NBR

Technical Specifications

Maximum Flow Rate	: 60 m ³ /h
Maximum Pressure	: 200 mwc
Connection Diameter	: 1 1/4" - 4"
Pressure Class	: PN25
Maximum Ambient Temperature	: 40°C
Fluid Temperature	: 0 °C - 40 °C
Fluid Quality	: Clean, solid particle-free, chemically neutral water

- Special bronze bushing resistant to operation without water
- Fully automatic electrical panel (sound and light alarm)
- 5m level floater that prevents the device dry running.
- Suction and delivery collector
- Spring-type stainless steel non return valve
- Manometer and pressure switch
- Steel frame with anti-vibration rubber chock and oven-dye
- Weekly test system

Y2 KO 10 / 7 - 30

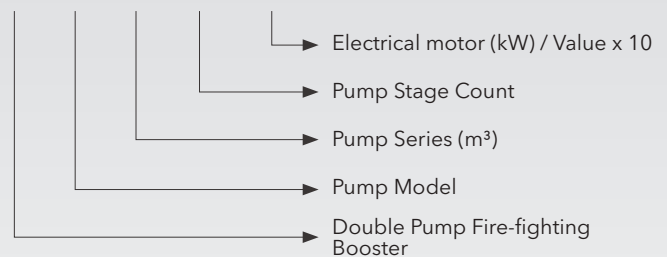

NOTE: Jokey (pilot) pump is optionally added to the KO 4/7 series water booster system in a compatible flow rate and pressure.

CAUTION:

- The use of recommended balance tank volume (100L) is only suitable for fire-fighting.
- Flex hose is not recommended for pressures equal to or higher than 16 bars.
- The fire pressure boosters should not be used to pressurize utility water. In case of use other than its intended purpose, the fire-fighting boosters will be out of warranty.



Y2 KO Series Technical Specifications



INVENTORY CODE	MODEL	POWER (HP)	NOMINAL CURRENT (AMBER)	H	FLOW (Q) m ³ /h			RECOMMENDED EXPANSION TANK	
					2x9	2x12	2x15	VOLUME	PRESSURE
080 2122 000	Y2 KO 10/5-22	2 x 3	2 x 4,9	Operating Pressure (bar)	61	48	27	200 lt	PN10
080 2124 000S	Y2 KO 10/S7-22	2 x 3	2 x 4,9		74	56	38	200 lt	PN10
080 2124 000	Y2 KO 10/7-30	2 x 4	2 x 6,2		86	66	39	300 lt	PN16
080 2126 000	Y2 KO 10/9-40	2 x 5,5	2 x 8		110	85	51	300 lt	PN16
080 2127 000	Y2 KO 10/10-40	2 x 5,5	2 x 8		125	95	59	300 lt	PN 16
080 2128 000	Y2 KO 10/12-55	2 x 7,5	2 x 10,9		153	122	81	300 lt	PN25**

INVENTORY CODE	MODEL	POWER (HP)	NOMINAL CURRENT (AMBER)	H	FLOW (Q) m ³ /h			RECOMMENDED EXPANSION TANK	
					2x12	2x15	2x18	VOLUME	PRESSURE
080 2221 000	Y2 KO 15/4-22	2 x 3	2 x 4,9	Operating Pressure (bar)	51	42	30	200 lt	PN10
080 2222 000	Y2 KO 15/5-30	2 x 4	2 x 6,2		64	53	37	200 lt	PN10
080 2223 000	Y2 KO 15/6-40	2 x 5,5	2 x 8		77	64	45	300 lt	PN10
080 2224 000	Y2 KO 15/7-40	2 x 5,5	2 x 8		90	79	56	300 lt	PN 16
080 2225 000	Y2 KO 15/8-55	2 x 7,5	2 x 10,9		107	90	67	300 lt	PN16
080 2226 000	Y2 KO 15/9-55	2 x 7,5	2 x 10,9		120	102	73	300 lt	PN16
080 2228 000	Y2 KO 15/12-75	2 x 10	2 x 14,1		161	137	95	500 lt	PN25**

INVENTORY CODE	MODEL	POWER (HP)	NOMINAL CURRENT (AMBER)	H	FLOW (Q) m ³ /h			RECOMMENDED EXPANSION TANK	
					2x18	2x24	2x30	VOLUME	PRESSURE
080 2320 000	Y2 KO 25/3-30	2 x 4	2 x 6,2	Operating Pressure (bar)	33	24	11	200 lt	PN10
080 2321 000	Y2 KO 25/4-40	2 x 5,5	2 x 8		45	35	18	300 lt	PN10
080 2323 000	Y2 KO 25/6-55	2 x 7,5	2 x 10,9		66	52	31	300 lt	PN10
080 2325 000	Y2 KO 25/8-75	2 x 10	2 x 14,1		92	71	41	500 lt	PN16
080 2327 000	Y2 KO 25/10-110	2 X 15	2 x 18,5		115	90	50	750 lt	PN16

INVENTORY CODE	MODEL	POWER (HP)	NOMINAL CURRENT (AMBER)	H	FLOW (Q) m ³ /h			RECOMMENDED EXPANSION TANK	
					2x25	2x30	2x35	VOLUME	PRESSURE
080 2420 000	Y2 KO 35/3-55	2x7,5	2x10,9	Operating Pressure (bar)	50	40	33	750 lt	PN10
080 2421 000	Y2 KO 35/4-75	2x10	2x14,1		64	55	40	750 lt	PN10
080 2422 000	Y2 KO 35/5-110	2x15	2x18,5		80	67	50	750 lt	PN10
080 2423 000	Y2 KO 35/6-110	2x15	2x18,5		92	77	60	750 lt	PN16
080 2424 000	Y2 KO 35/7-150	2x20	2x28,5		112	92	70	750 lt	PN16
080 2425 000	Y2 KO 35/8-150	2x20	2x28,5		130	108	80	750 lt	PN16

INVENTORY CODE	MODEL	POWER (HP)	NOMINAL CURRENT (AMBER)	H	FLOW (Q) m ³ /h			RECOMMENDED EXPANSION TANK	
					2x35	2x45	2x55	HACİM	BASINÇ
080 2520 000	Y2 KO 45/3-110	2x15	2x18,5	Operating Pressure (bar)	57	53	45	1000 lt	PN10
080 2521 000	Y2 KO 45/4-110	2x15	2x18,5		77	70	60	1000 lt	PN10
080 2522 000	Y2 KO 45/5-150	2x20	2x28,5		95	85	72	1000 lt	PN16
080 2523 000	Y2 KO 45/6-185	2x25	2x32,5		112	105	88	1000 lt	PN16

** Safety switch is added to prevent the booster system to exceed 16 bars. PN 16 expansion tank is used for these systems.

- Flex hose is not recommended for pressures equal to or higher than 16 bars.
- Stopping pressure is minimum 1.5 bar higher than the starting pressure.
- Suction collector included.
- Consult to our firm if the booster will suck water from a negative level.

Y2 KO Series Hydraulic Performance Curves

KO 10 Series

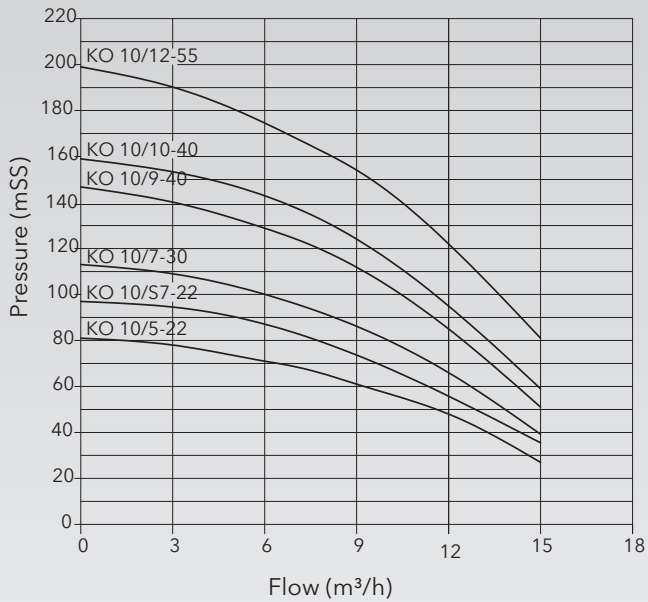

KO 15 Series

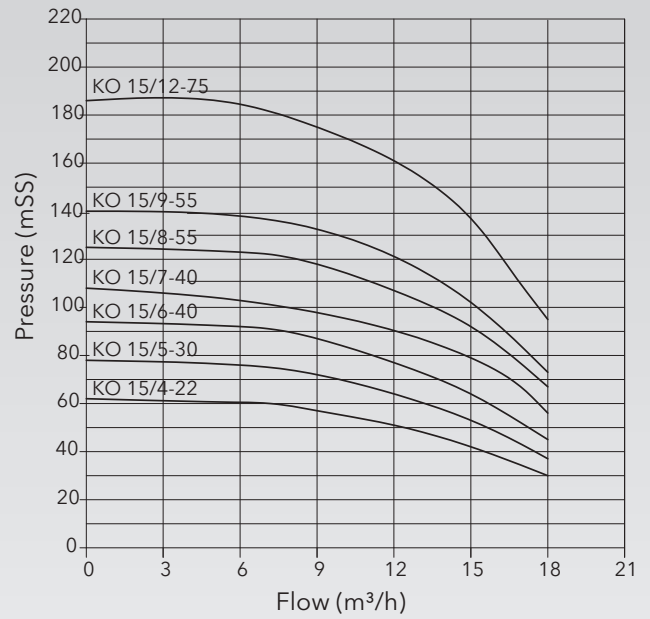

KO 25 Series

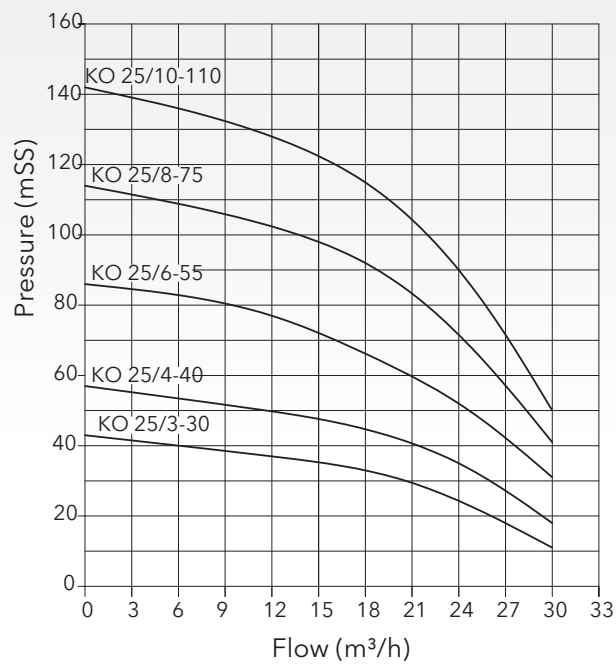

KO 35 Series

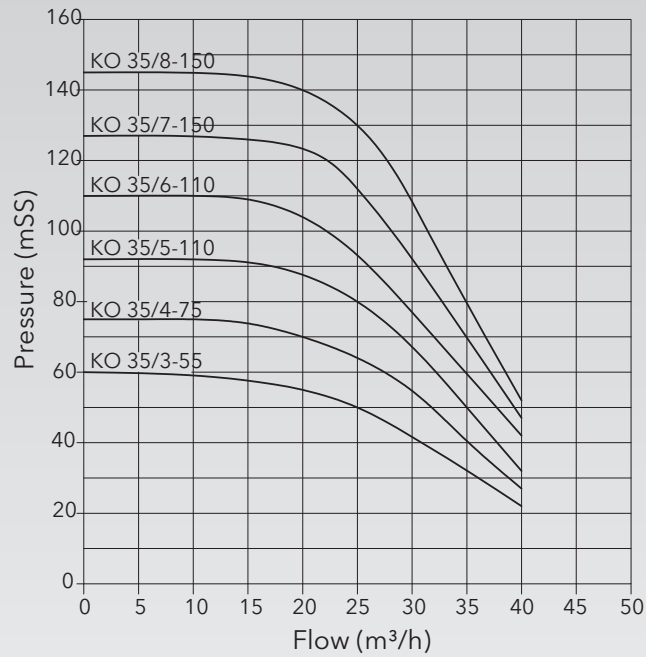

KO 45 Series

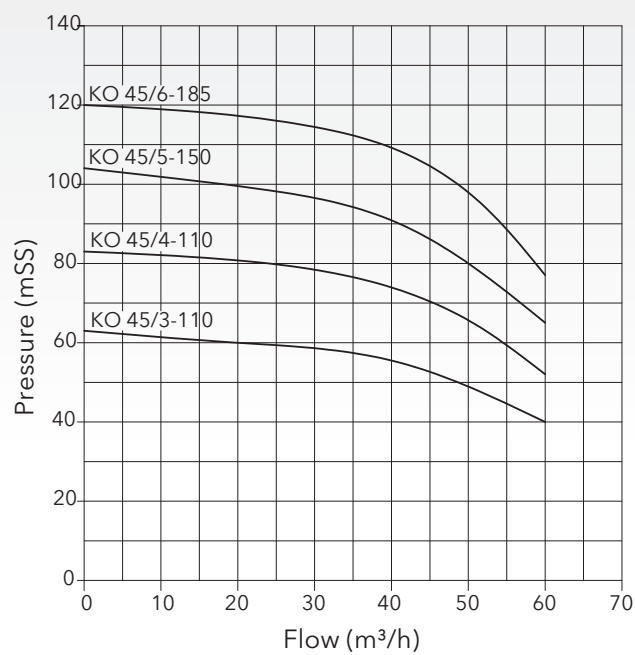

Y2 KO Series Dimensions

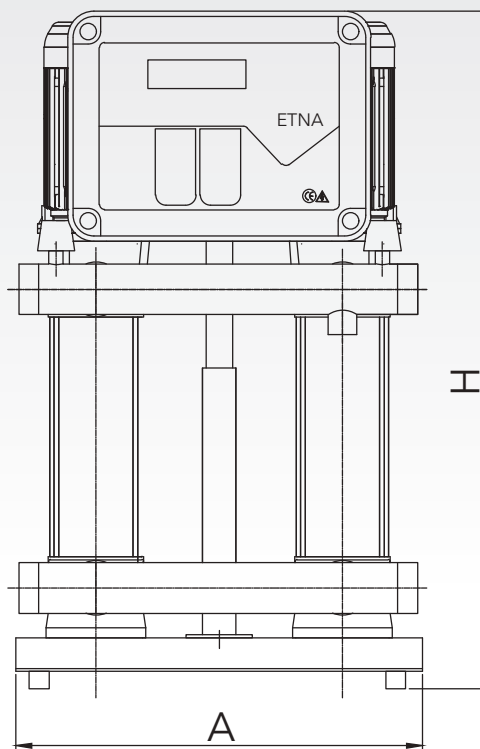
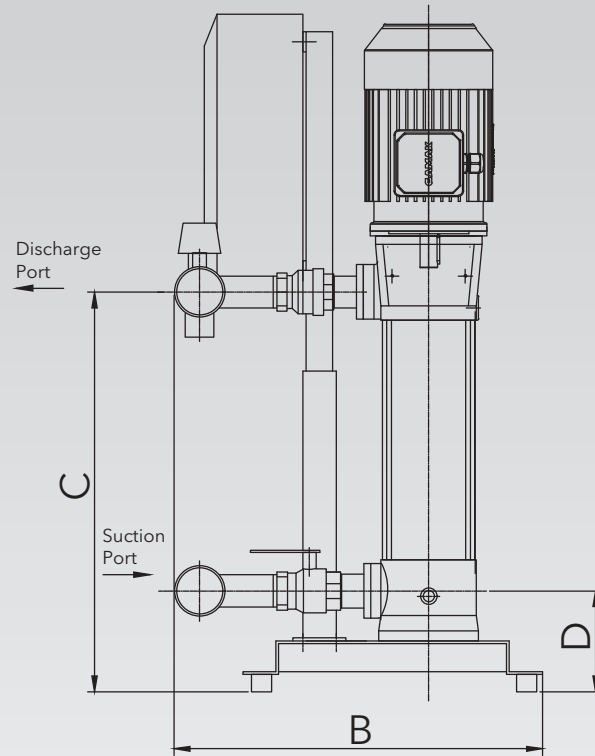

MODEL	DIMENSIONS						
	Suction Diameter	Discharge Diameter	A	B	C	D	H
Y2 KO 10/5-22	2"	2"	670	530	411	130	800
Y2 KO 10/7S-22	2"	2"	670	530	487	130	852
Y2 KO 10/7-30	2"	2"	670	530	487	130	852
Y2 KO 10/9-40	2"	2"	670	530	572	130	963
Y2 KO 10/10-40	2"	2"	670	530	610	130	1000
Y2 KO 10/12-55	2"	2"	670	530	687	130	1100

MODEL	DIMENSIONS						
	Suction Diameter	Discharge Diameter	A	B	C	D	H
Y2 KO 15/4-22	2"	2"	670	530	373	130	800
Y2 KO 15/5-30	2"	2"	670	530	411	130	800
Y2 KO 15/6-40	2"	2"	670	530	457	130	855
Y2 KO 15/7-40	2"	2"	670	530	495	130	895
Y2 KO 15/8-55	2"	2"	670	530	533	130	950
Y2 KO 15/9-55	2"	2"	670	530	572	130	990
Y2 KO 15/12-75	2"	2"	670	530	686	130	1100

MODEL	DIMENSIONS						
	Suction Diameter	Discharge Diameter	A	B	C	D	H
Y2 KO 25/3-30	2 1/2"	2 1/2"	670	530	393	165	800
Y2 KO 25/4-40	2 1/2"	2 1/2"	670	530	457	165	860
Y2 KO 25/6-55	2 1/2"	2 1/2"	670	530	572	165	990
Y2 KO 25/8-75	2 1/2"	2 1/2"	670	530	686	165	1100
Y2 KO 25/10-110	2 1/2"	2 1/2"	480	750	800	150	1220

MODEL	DIMENSIONS						
	Suction Diameter	Discharge Diameter	A	B	C	D	H
Y2 KO 35/3-55	3"	2 1/2"	670	780	468	190	880
Y2 KO 35/4-75	3"	2 1/2"	670	780	514	190	925
Y2 KO 35/5-110	3"	2 1/2"	650	750	559	185	1070
Y2 KO 35/6-110	3"	2 1/2"	650	750	605	185	1115
Y2 KO 35/7-150	3"	2 1/2"	650	750	651	185	1265
Y2 KO 35/8-150	3"	2 1/2"	650	750	696	185	1310

MODEL	DIMENSIONS						
	Suction Diameter	Discharge Diameter	A	B	C	D	H
Y2 KO 45/3-110	4"	3"	650	750	551	190	1060
Y2 KO 45/4-110	4"	3"	650	750	613	190	1120
Y2 KO 45/5-150	4"	3"	650	750	695	190	1310
Y2 KO 45/6-185	4"	3"	650	750	757	190	1370

Residential Water Boosters with Alarm Kits Y-KO + Diesel Series

Residential water booster system for fire with alternative power supply (diesel) in case of power failure. Applicable for fire-fighting systems of commercial buildings such as houses and apartment blocks.

Product Specifications

The set is composed of a diesel engine and an electrical motor pump (Pilot (jokey) pump is optional). It is provided as a set on a spray painted chassis with pumps connected to each other with manifold, a shock absorber, ball valves, check valves, individual pressure switches and a control panel with weekly test cycle.

Operating Principles

The pump is activated when there is a pressure drop in the system. And the diesel engine pump is automatically activated when the power is cut or the water demand increases.



Fire Pressure Booster Panel

Technical Specifications

Maximum Flow Rate	: 15 m ³ / h
Maximum Pressure	: 113 mwc
Connection Diameter	: 2"
Pressure Class	: PN25
Maximum Ambient Temperature	: 0-40°C
Fluid Quality	: Clean, solid particle-free, chemically neutral water

Electrical Pump Properties

Pump Casing	: AISI304 Stainless Steel
Pump Fan	: Noryl
Pump Shaft	: AISI420 Stainless Steel
Suction-Discharge Body	: Cast Iron
Seal	: Mechanical

Electric Motor Specifications

Type	: Asynchronous, Triphase Electric Motor
Electric Supply	: 3*380V, 50 Hz
Number of Cycles	: 2900 rpm
Electric Motor Power	: 3kW
Electric Motor Efficiency	: IE3
Protection Class	: IP55
Insulation Class	: F

Diesel Pump Properties

Pump Casing	: Cast Iron
Pump Fan	: Aluminum
Pump Shaft	: AISI304 Stainless Steel
Suction-Discharge Diameter	: 2"
Seal	: Mechanical

Diesel Engine Specifications

Type	: 4-Stroke, Single Cylinder, Air-Cooled, Diesel Engine
Supply Voltage	: 12 Volt DC (battery)
Number of Cycles	: 2950 rpm
Diesel Engine Power	: 10 hp
Fuel Tank	: 5l

Y KO 10 / 7 30 / D10 + 1 KO 4/8-15

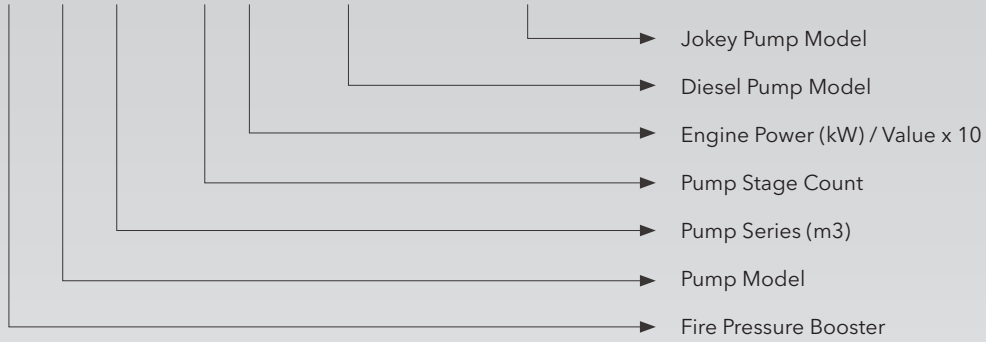

NOTE: Jokey (pilot) pump is optionally added to the 1 KO 4/8-15 water booster system.

CAUTION:

- The use of recommended expansion tank volume (100L) is only suitable for fire-fighting.
- Flex hose is not recommended for pressures equal to or higher than 16 bars.
- The fire pressure boosters should not be used to pressurize utility water. In case of use other than its intended purpose, the fire-fighting boosters will be out of warranty.

YKO 10/7-30 / D10 + 1 KO 4/8-15 (Optional)

MODEL	POWER (HP)		FLOW (Q) m ³ /h	PRESSURE (mSS)	RECOMMENDED TANK VOLUME
	Electrical	Diesel			
YKO 10/7-30 / D10 (Electrical) + (Diesel)	4	10	12	65	300 LT PN 16
Pilot (Jockey) Pump: 1 KO 4/8-15 (OPTIONAL)	2	-	3	75	

Y-KO + Diesel Series Dimensions

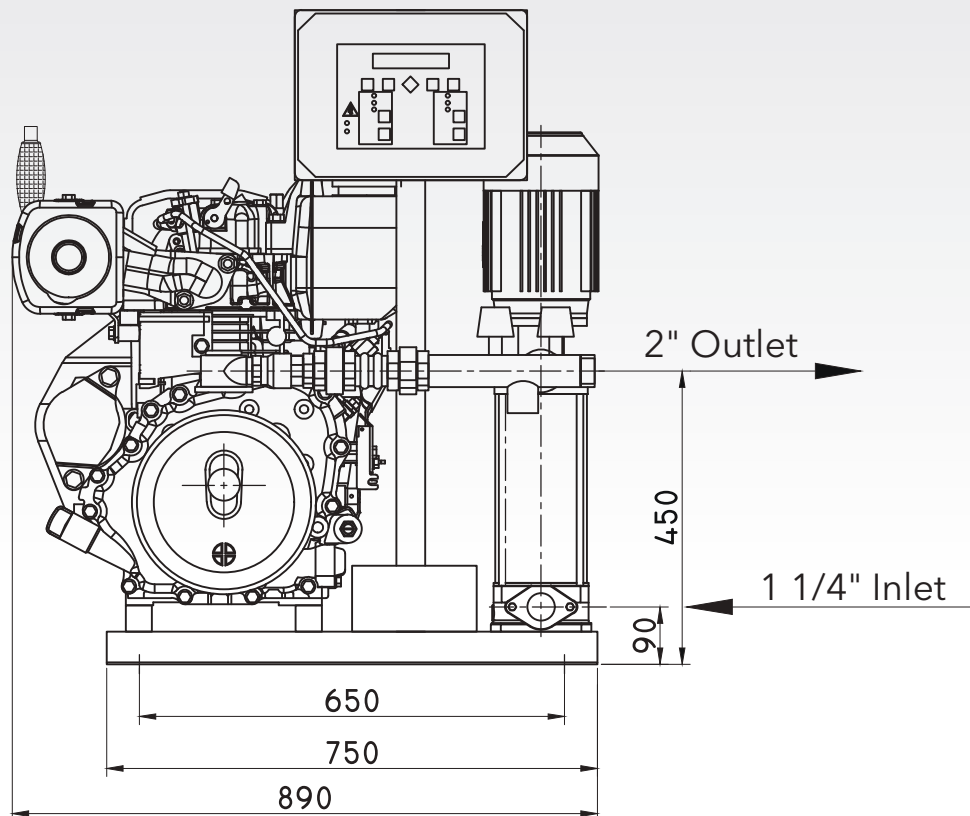
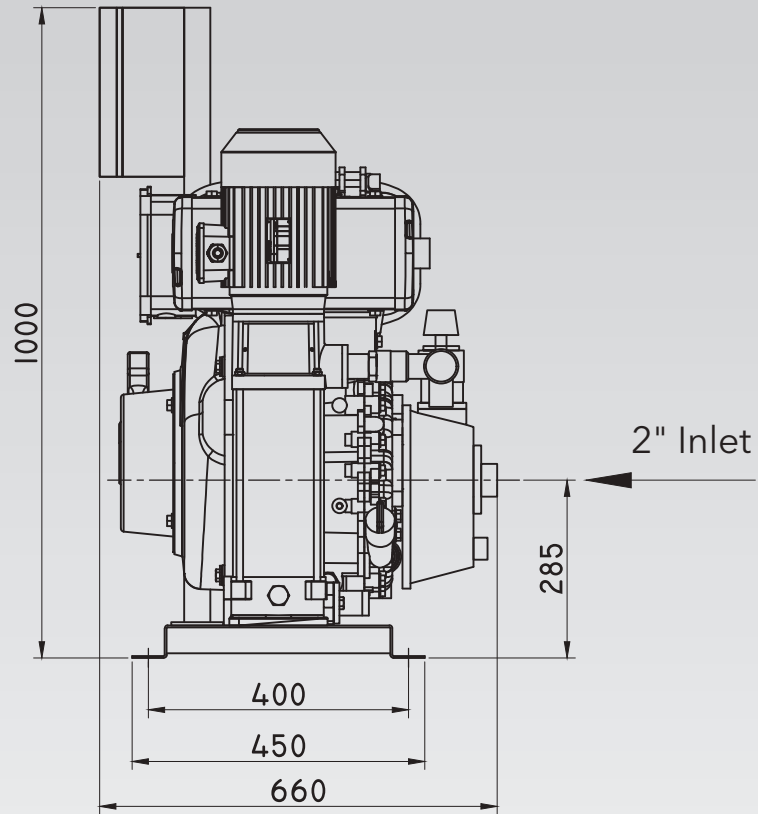

Fire pressure booster system for residential & commercial use with alternative power supply (diesel) as a precaution to power failure. Used in fire-fighting systems at spaces such as villas, apartments, fuel stations, warehouses, small scale industrial facilities.

Product Specifications:

Water booster system is composed of 1 (one) diesel engine, 1 (one) electrical pump, 1 (one) jokey pump. It is provided as a set with pumps connected to collectors, a vibration absorber, ball valves, non return valves, individual pressure switches and a control panel with weekly test cycle.

Operating Principles:

First jokey pump steps in to fulfill the water need of the system in case of fire. If there is a fire and the pressure starts to drop, the main pump is activated. In case the water demand increases, diesel engine pump steps in automatically.



Fire Pressure Booster Panel

Technical Specifications

Maximum Flow Rate	: 30 m ³ /h
Maximum Pressure	: 145 mwc
Connection Diameter	: 2 1/2"
Pressure Class	: PN25
Maximum Ambient Temperature	: 0-40°C
Fluid Quality	: Clean, solid particle-free, chemically neutral water

Electrical Pump Properties

Pump Casing	: AISI304 Stainless Steel
Pump Fan	: Noryl
Pump Shaft	: AISI420 Stainless Steel
Suction-Discharge Body	: Cast Iron
Seal	: Mechanical

Electric Motor Specifications

Type	: Asynchronous, Triphase Electric Motor
Electric Supply	: 3*380V, 50 Hz
Number of Cycles	: 2900 rpm
Electric Motor Power	: 3-7.5 kW
Electric Motor Efficiency	: IE3
Protection Class	: IP55
Insulation Class	: F

Diesel Pump Properties

Pump Casing	: Cast Iron
Pump Fan	: Aluminum
Pump Shaft	: AISI304 Stainless Steel
Seal	: Mechanical

Diesel Engine Specifications

Type	: 4-Stroke, Single Cylinder, Air Cooled, Diesel Engine
Supply Voltage	: 12 Volt DC (battery)
Number of Cycles	: 2950 rpm
Diesel Engine Power	: 10 hp
Fuel Tank	: 5lt

- Suitable for systems containing fire cabinets.
- Automatic test system is available.
- Connection flex and expansion tank excluded.

Residential Water Boosters with Alarm Kits

Y-KO + Diesel (Horizontal) Series

Y2 KO 10 / 7 30 / D10 + KO 4/8

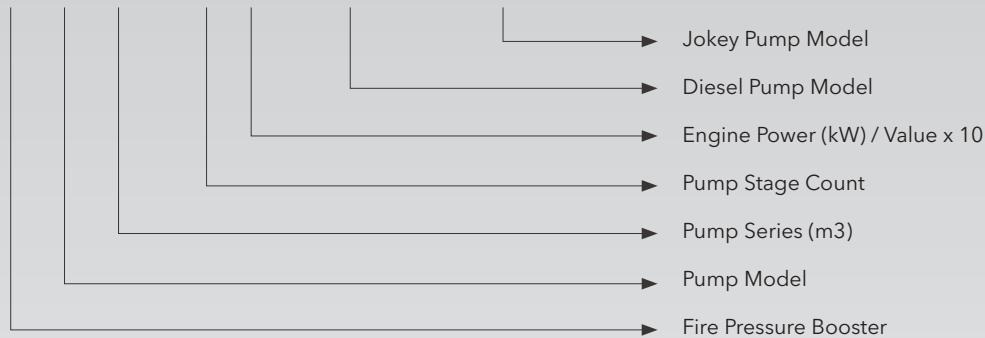

CAUTION:

- The use of recommended balance tank volume (100L) is only suitable for fire-fighting.
- The fire pressure boosters should not be used to pressurize utility water. In case of use other than its intended purpose, the fire-fighting boosters will be out of warranty.

MODEL	POWER (HP)		RATED CURRENT (AMPERES)	N	FLOW RATE (Q) m ³ /h			RECOMMENDED TANK	
	Electric	Diesel			2x9+2.4	2x12+3.6	2x15+4.8	VOLUME	PRESSURE
Y2 KO 10/7-30+D10+KO 4/8	4	10	6.2	Operating Pressure (mWC)	86	66	39	100 L	PN 16
Y2 KO 10/9-40+D10+KO 4/9	5.5	10	8		110	85	51	100 L	PN 16

MODEL	POWER (HP)		RATED CURRENT (AMPERES)	N	FLOW RATE (Q) m ³ /h			RECOMMENDED TANK	
	Electric	Diesel			2x12+2.4	2x15+3.6	2x18+4.8	VOLUME	PRESSURE
Y2 KO 15/6-40+D10+KO 4/8	5.5	10	8	Operating Pressure (mWC)	77	64	45	100 L	PN 10
Y2 KO 15/8-55+D10+KO 4/9	7.5	10	10.9		107	90	67	100 L	PN 16
Y2 KO 15/9-55+D10+KO 4/9	7.5	10	10.9		120	102	73	100 L	PN 16

MODEL	POWER (HP)		RATED CURRENT (AMPERES)	N	FLOW RATE (Q) m ³ /h			RECOMMENDED TANK	
	Electric	Diesel			2x18+2.4	2x24+3.6	2x30+4.8	VOLUME	PRESSURE
Y2 KO 25/6-55+D10+KO 4/9	7.5	10	10.9	Operating Pressure (mWC)	66	52	31	100 L	PN 10
Y2 KO 25/8-75+D10+KO 4/9	10	10	14.1		92	71	41	100 L	PN 16

MODEL	POWER (HP)		RATED CURRENT (AMPERES)	N	FLOW RATE (Q) m ³ /h			RECOMMENDED TANK	
	Electric	Diesel			2x9	2x12	2x15	VOLUME	PRESSURE
Y2 KO 10/7-30+D10 WITHOUT PILOT	4	10	6.2	Operating Pressure (mWC)	86	66	39	300 L	PN 16
Y2 KO 10/9-40+D10 WITHOUT PILOT	5.5	10	8		110	85	51	300 L	PN 16

MODEL	POWER (HP)		RATED CURRENT (AMPERES)	N	FLOW RATE (Q) m ³ /h			RECOMMENDED TANK	
	Electric	Diesel			2x12	2x15	2x18	VOLUME	PRESSURE
Y2 KO 15/6-40+D10 WITHOUT PILOT	5.5	10	8	Operating Pressure (mWC)	77	64	45	300 L	PN 10
Y2 KO 15/8-55+D10 WITHOUT PILOT	7.5	10	10.9		107	90	67	300 L	PN 16
Y2 KO 15/9-55+D10 WITHOUT PILOT	7.5	10	10.9		120	102	73	300 L	PN 16

Residential Water Boosters with Alarm Kits Y-KO + Diesel (Horizontal) Series Dimensions

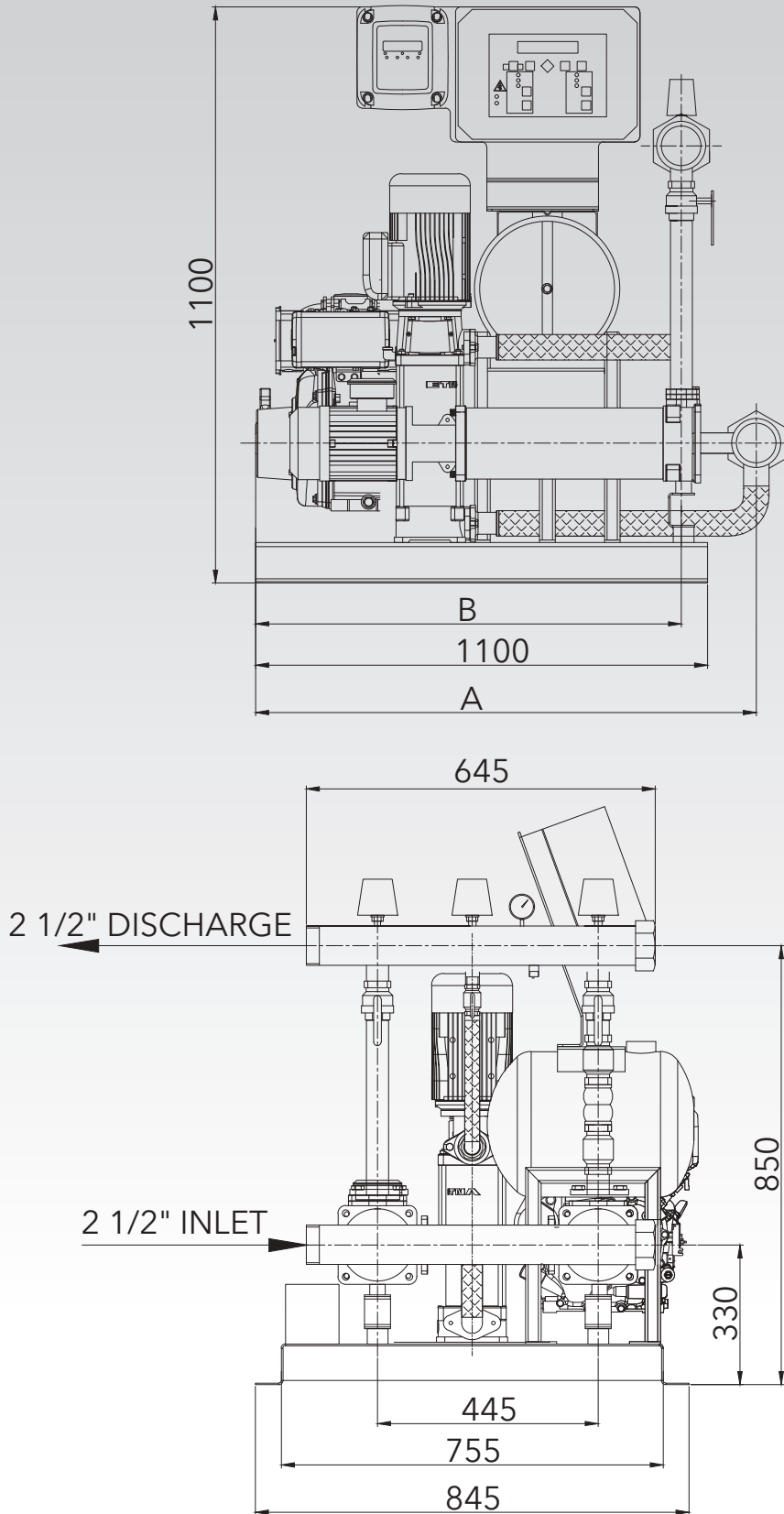

Mobile Fire Extinguishing and Flood Discharging Pump HIZIR Series

ETNA HIZIR series standing out with fast installation and intervention advantage protects your investment.

ETNA HIZIR mobile fire extinguishing and flood discharge pump is designed and manufactured to fulfill the mobile fire extinguishing or flood discharging needs of marinas, ports, plants, fuel stores, natural disaster stations etc. They can be fastened to the back of a truck or any other motor vehicle to be transferred to the site and are ready to start extinguishing fire or discharging flood within minutes.

If they will be used for fire-fighting, they should be transferred with a water tank or moved near a water source (such as tank/well/fire-fighter suction nozzle). If they will be used for collecting discharging water, they should be moved near the flood site, the suction hoses should be placed under water and the exhaust vacuum system should be started to fill the pump suction line with water.

Trailer

Two-wheel, highway trailer (highway certificate is optional) with tow bar and brake equipment



Operation Panel

On the panel placed to operate the diesel engine, there are oil pressure, water temperature, fuel, engine cycle indicators, engine key and throttle lever.

Accessories

Two 2" and 3m suction hoses. 2" and 20m delivery hoses, claw pipe connections, water spray lance, two-way flap inlet pipe on the pump, two-way valve controlled outlet pipe.

Startup

Can be used against fire or flood. In both cases, a vehicle should be brought to the site. Suction hose and delivery hose may be easily connected to the suction and delivery flanges with the help of claw couplings. Suction hose is placed inside a pool, lagoon or water reserve, or connected to a water tank. Diesel engine is started with the help of the electrical start motor, vacuum is created inside the pump with the help of the exhaust gas venturi valve by closing the exhaust guide lever, water is primed inside the pump after 30-40 seconds and pump gets ready to deliver water. Then the exhaust guide lever is returned back to its original position and the hose begins to spray water. It may also be used for extinguishing fire by spraying foam instead of water where explosive, flammable substances are seen by using foam mixer, if requested.

If the pump will be used for flood, the suction hose is placed to the affected site and the same steps are repeated to discharge water rapidly. The pumps is not suitable for priming water from cesspools. The pump is used to discharge grey water with few particulates.

The pump is not suitable for agricultural irrigation or water transfer.

HIZIR 90/41

Pump Specifications	
Flow Rate	90 m ³ / h
Pressure	90 mwc
Type	EA 50/26
Suction Diameter	DN 65 mm (Flange)
Discharge Diameter	DN 50 mm (Flange)
Seal	Mechanical
Casing	GG25 Cast Iron
Impeller Diameter	268 mm Bronze

Diesel engine: 42 kW, 2900 rpm, four-stroke, water-cooled, kick-starter, four cylinders (ETNA OEM brand)

HIZIR 120/65

Pump Specifications	
Flow Rate	120 m ³ / h
Pressure	90 mwc
Type	EA 65/26
Suction Diameter	DN 80 mm (Flange)
Discharge Diameter	DN 65 mm(Flange)
Seal	Mechanical
Casing	GG25 Cast Iron
Impeller Diameter	268 mm Bronze

Diesel engine: 65 kW, 2900 rpm, four-stroke, water-cooled, kick-starter, four cylinders (ETNA OEM brand)



Suction Hose 3m



Delivery Hose 20m

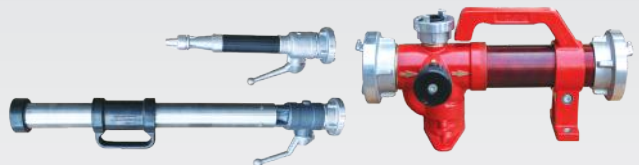

Foam Mixer (Optional)

Dimensions

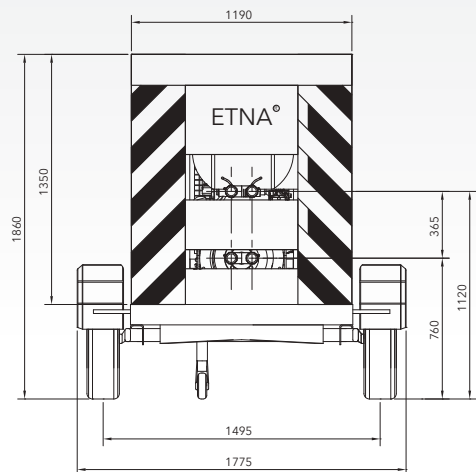
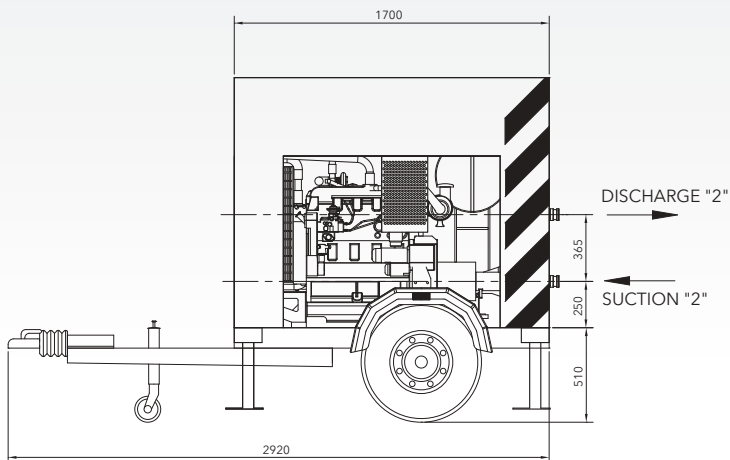

Rev. 09/2024



Dudullu Organize Sanayi Bölgesi 2. Cadde No: 14
34775 Ümraniye İstanbul / Turkey
Tel : +90 216 561 47 74 (Pbx) • Fax : +90 216 561 47 50
www.etna.com.tr/en • info@etna.com.tr



ETNA®

0850 455 38 62
customer service