



Horizontal Split Case Pumps
✓ **ESC Series**

ESC series horizontal split case pumps with high efficiency and durability offer high performance in high flow applications. It has double suction which reduces axial force at suction. Discharge and suction flanges are on the same axis. The pump consists of two parts, top and bottom and is connected to each other by bolts. Without disconnecting the pump from the pipe installation these bolts can be removed and repair and maintenance operations can be done easily.

Areas of Usage

- Water Supply, Treatment and Pressurization
- Fire Fighting
- Agricultural Irrigation and Drainage
- HVAC
- Industrial facilities
- Mining
- Marine and Ship Applications

Pump Specifications

- Pump Body : GG25 Cast Iron
- Pump Shaft : AISI420 Stainless Steel
- Impeller : Bronze
- Sealing Type : Mechanical Seal (ops. Soft Packing)

Technical Specifications

- Max. Flow Rate : 1250 m3/h
- Max. Discharge Head : 225 mwc
- Flange : DIN 2501
- Connection : DN80 - DN200
- Max. Operating Pressure : 25 Bar
- Max. Ambient Temp. : 40°C
- Temp. of Pumped Liquid : 0 - 105°C
- Fluid Quality : Clean, solid abrasive particle-free, non-hard chemically neutral water

Motor Specifications

- Network Connection : 3*400V, 50Hz
- Motor Speed : 2900 rpm
- Motor Power : 90 - 315 kW
- Motor Efficiency : IE2
- Protection Class : IP55
- Insulation Class : F

Pump Identification Code

ESC MK 125 290 2900

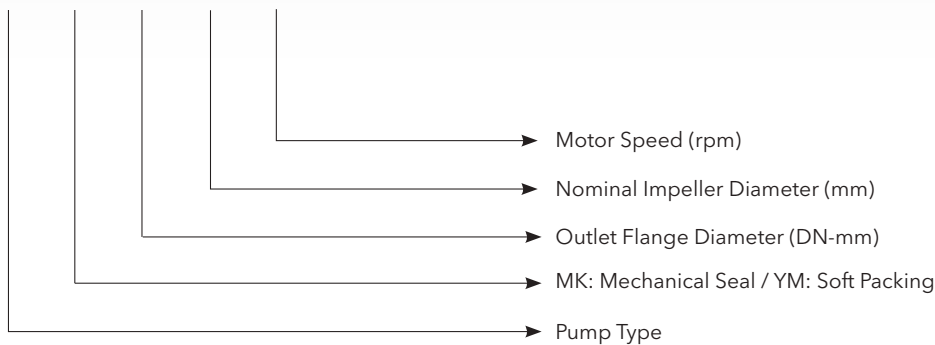

Family of Curves- 2900 rpm - 50 Hz

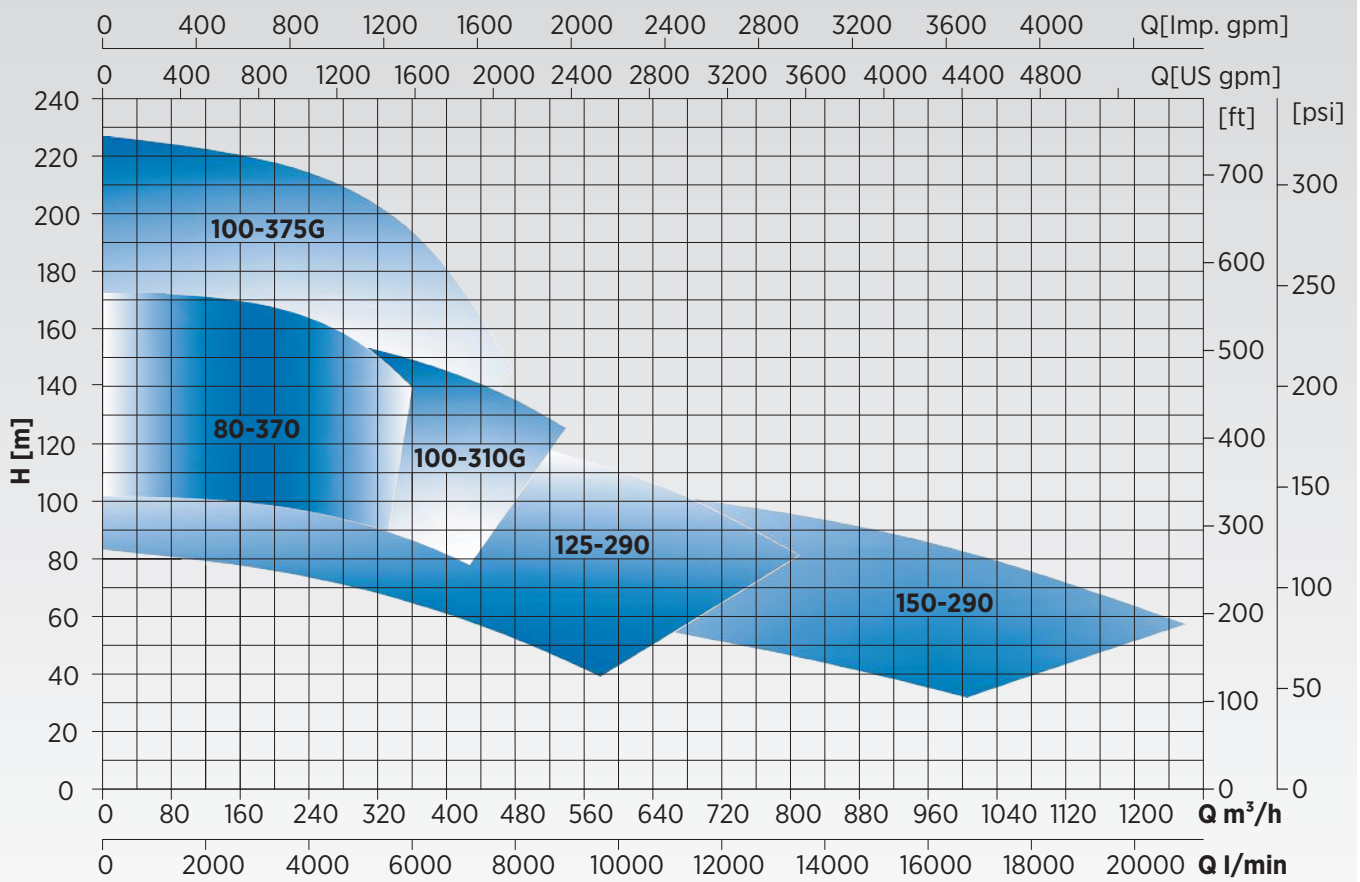

Performance Curves

ESC 80-370 Series

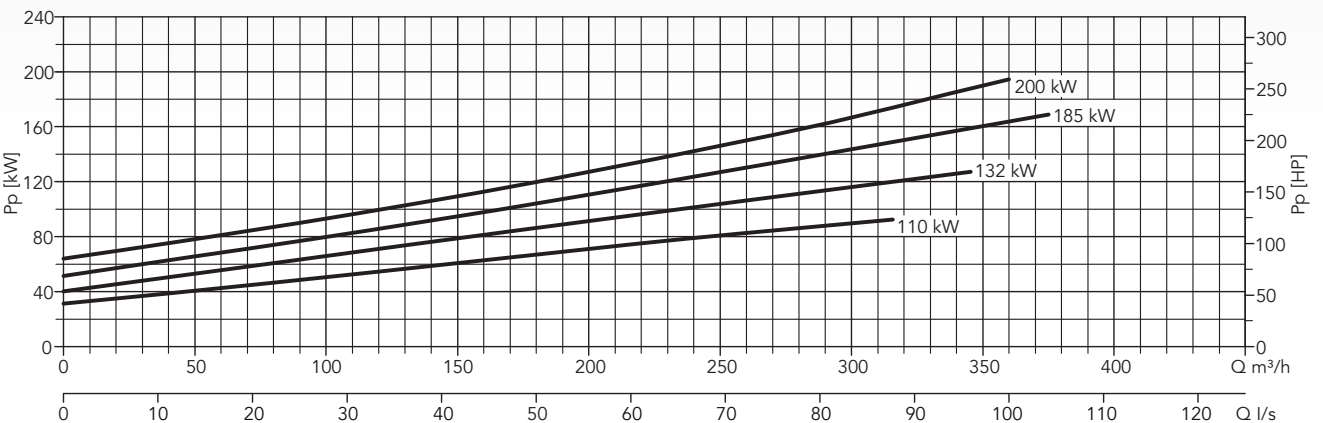
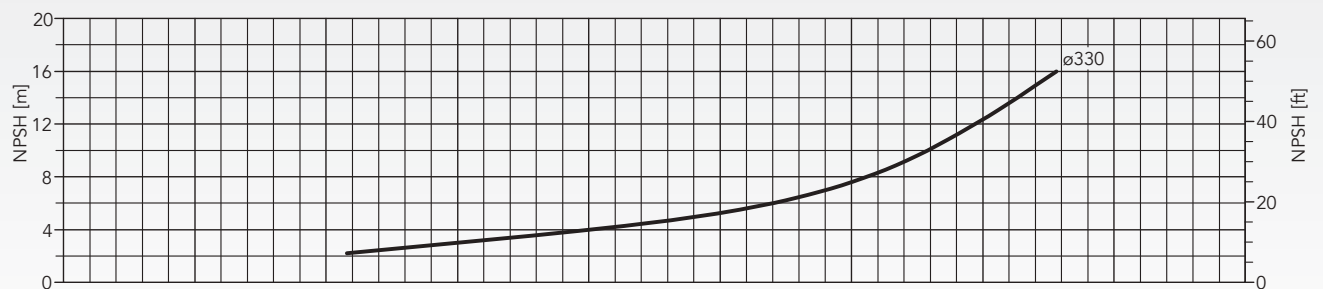
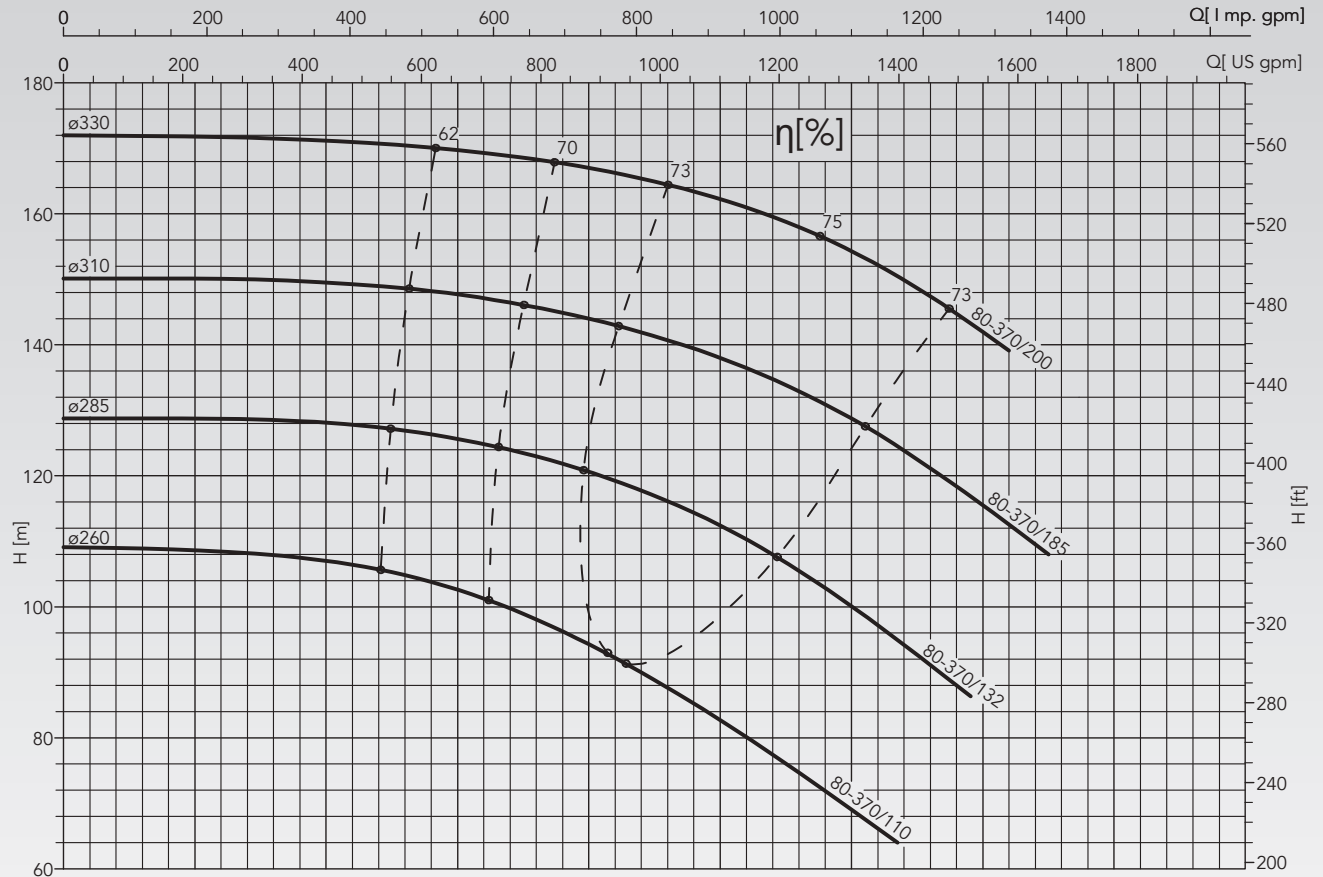

Performance Curves

ESC 100-310G Series

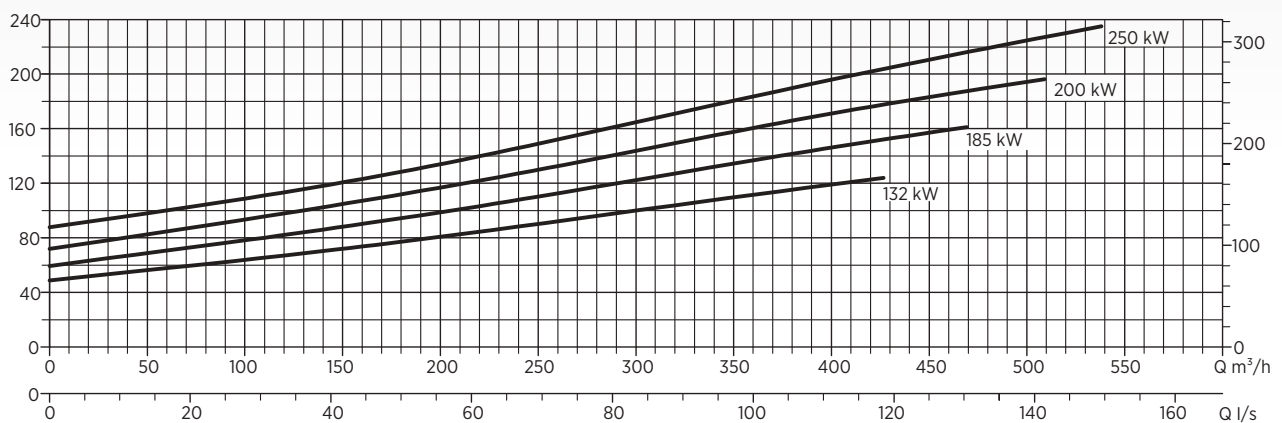
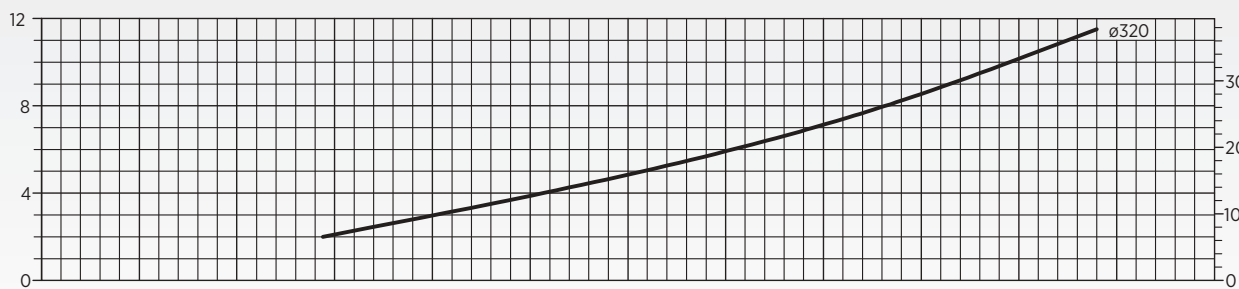
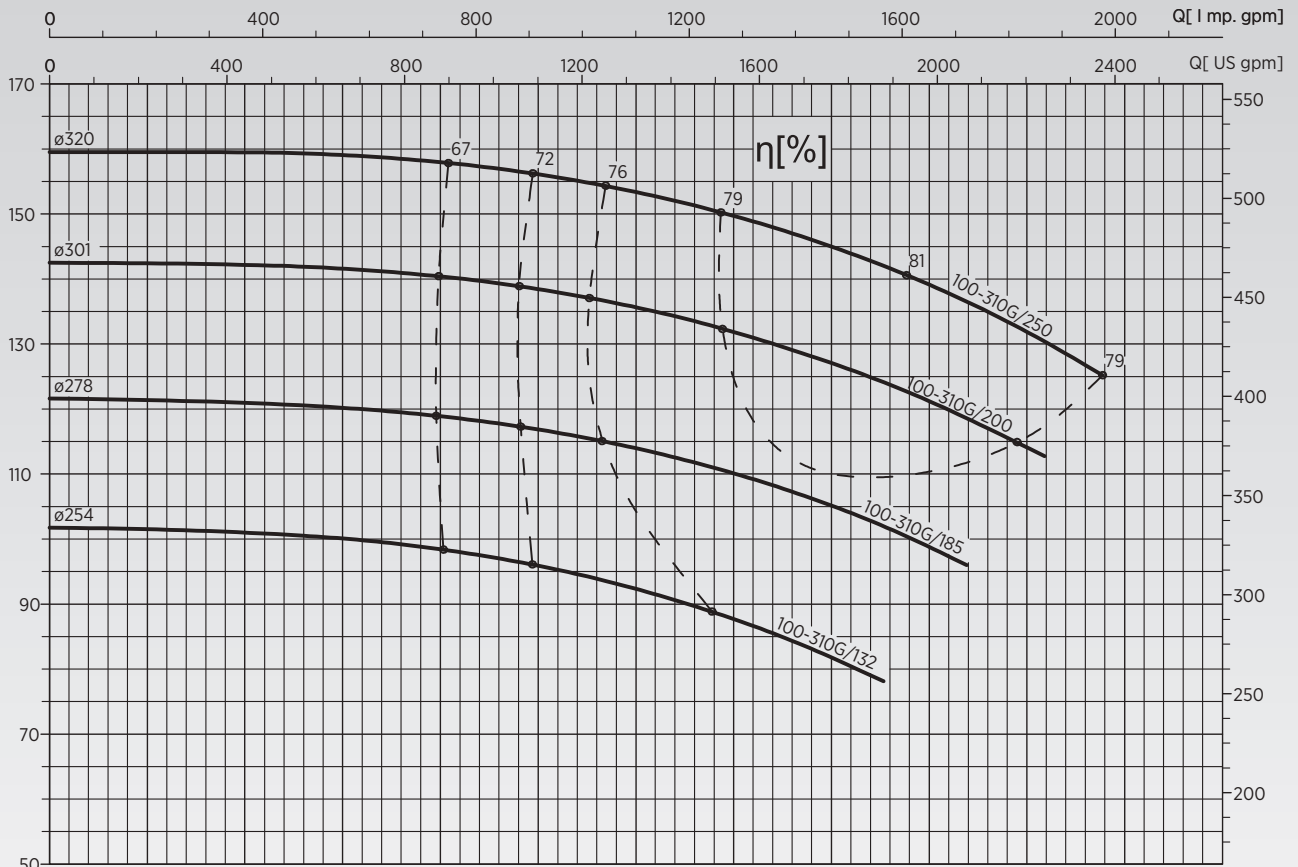

Performance Curves

ESC 100-375G Series

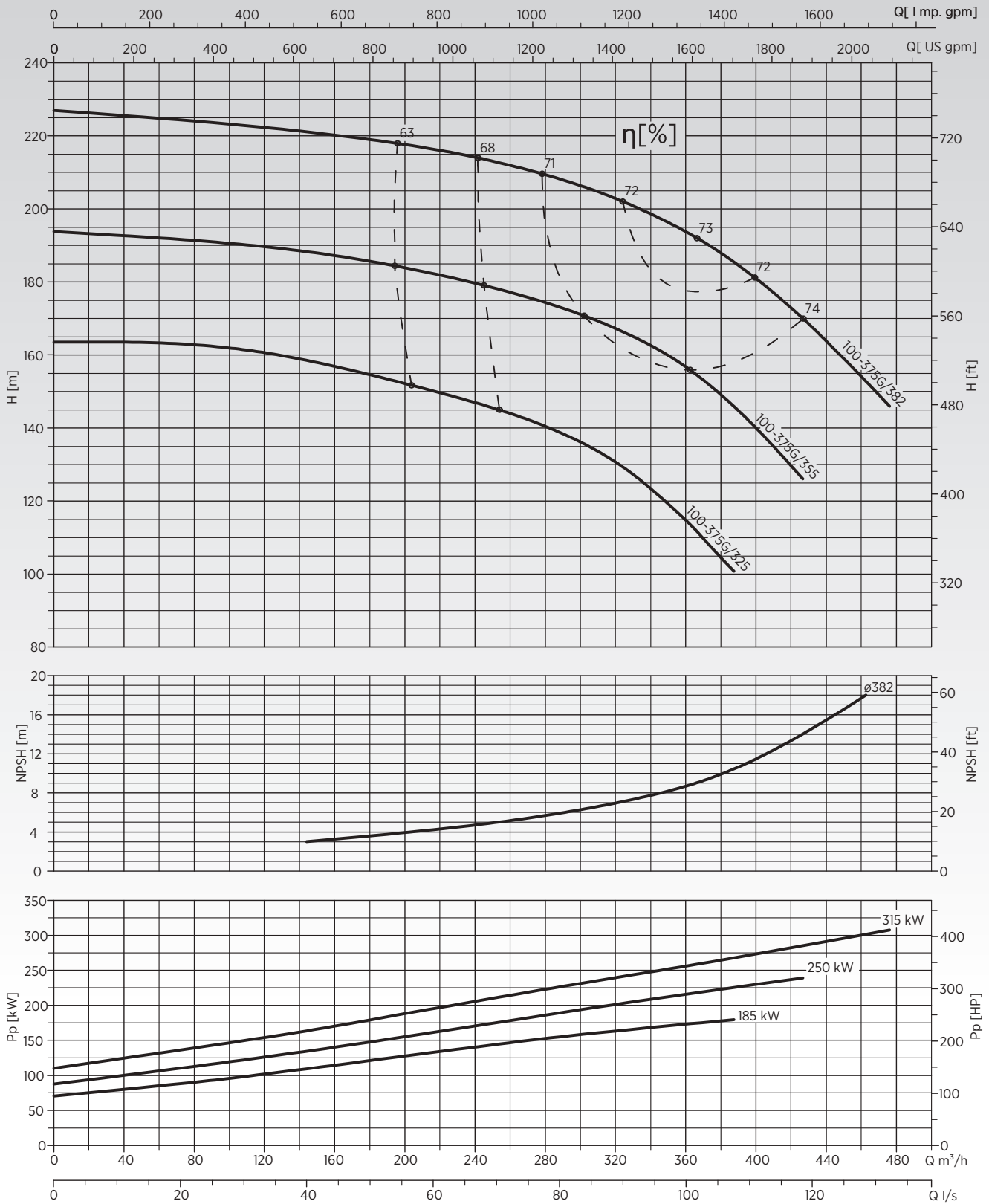

Performance Curves

ESC 125-290 Series

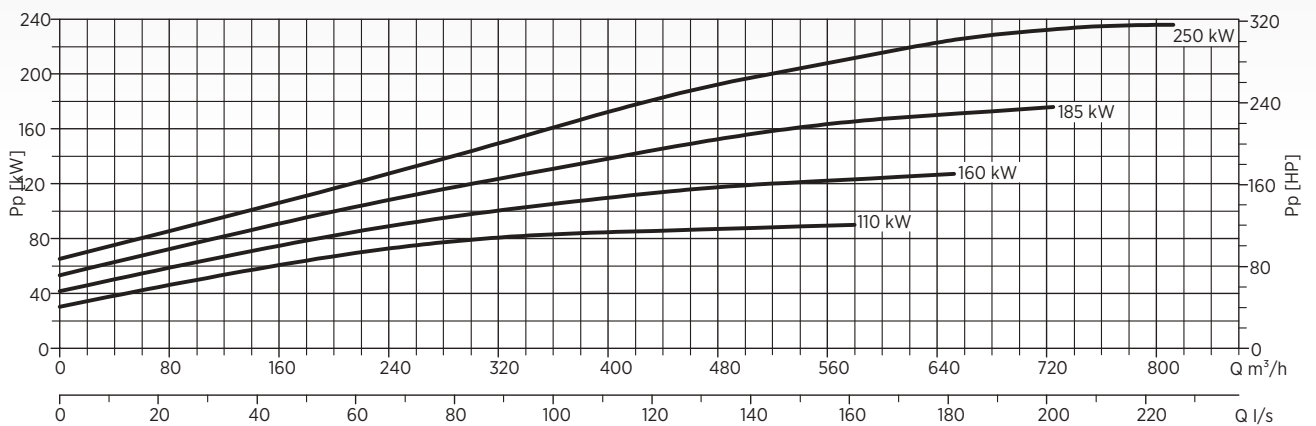
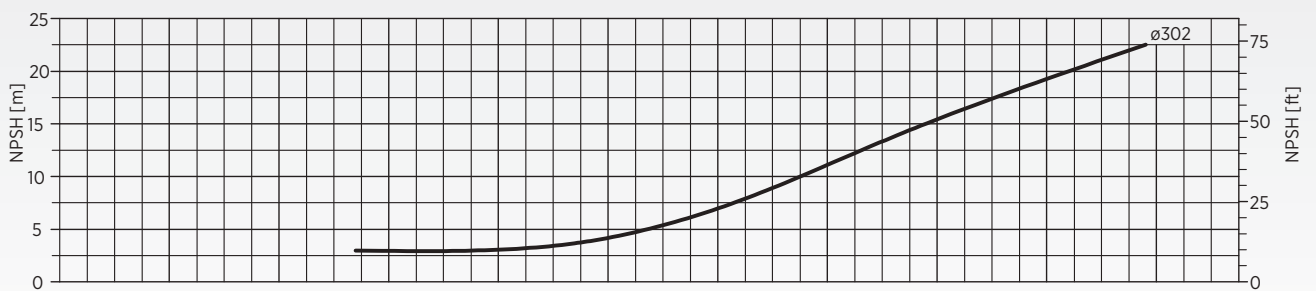
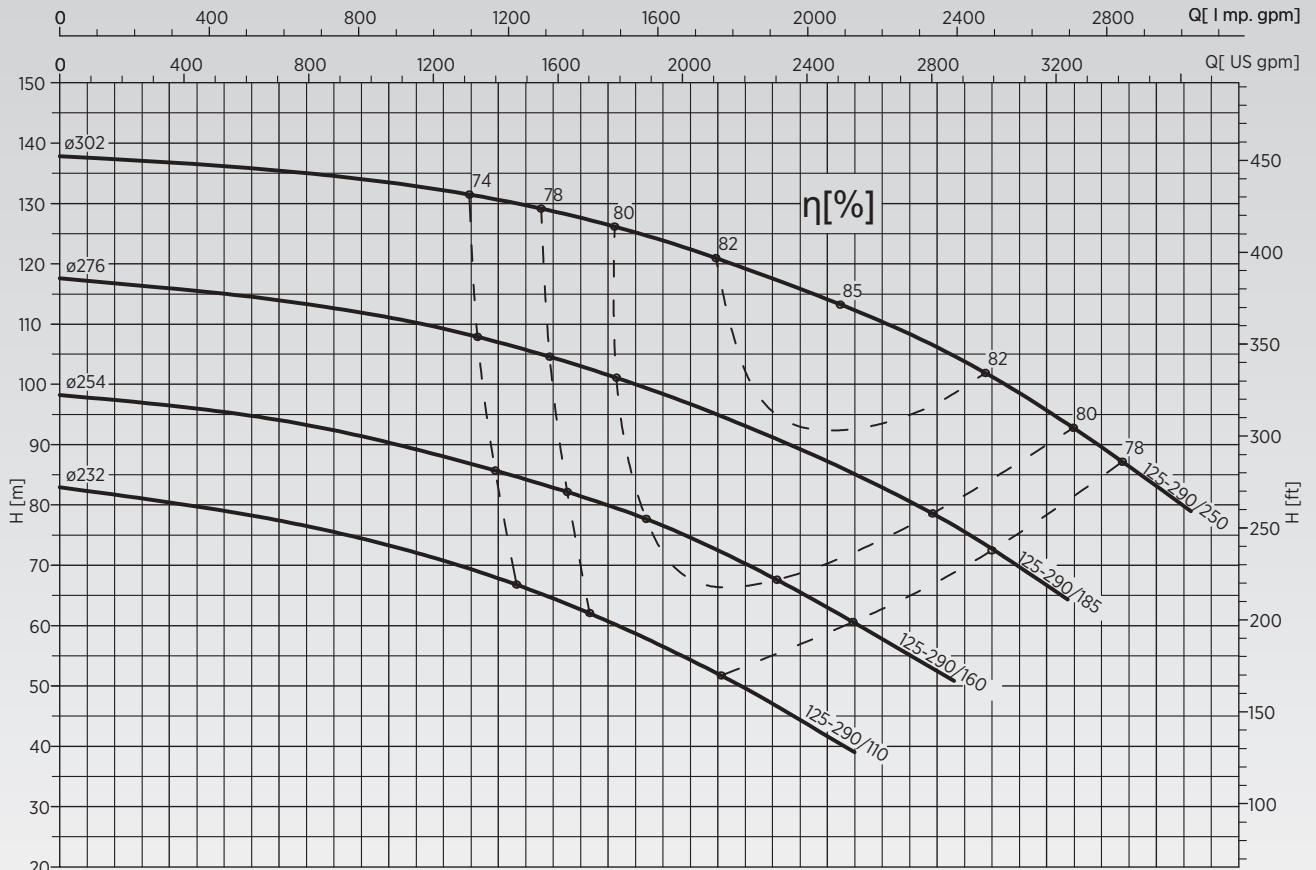

Performance Curves

ESC 150-290 Series

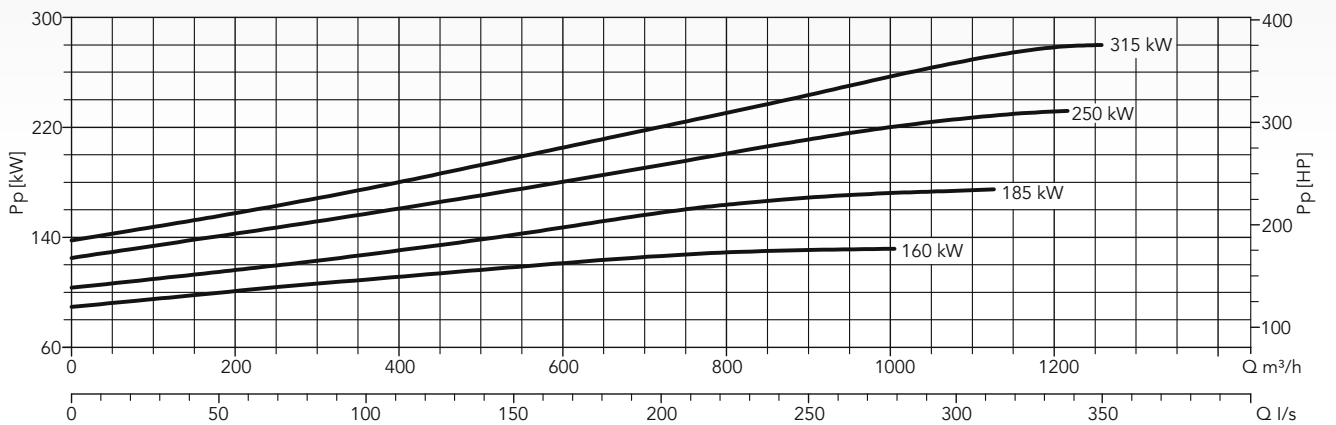
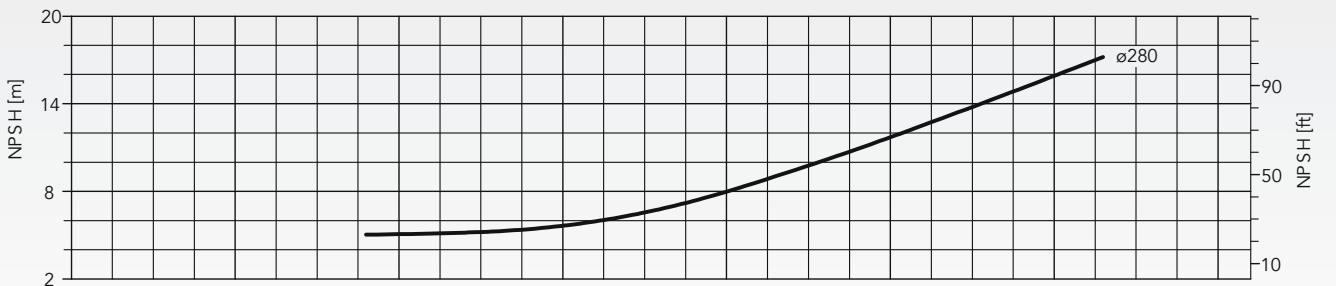
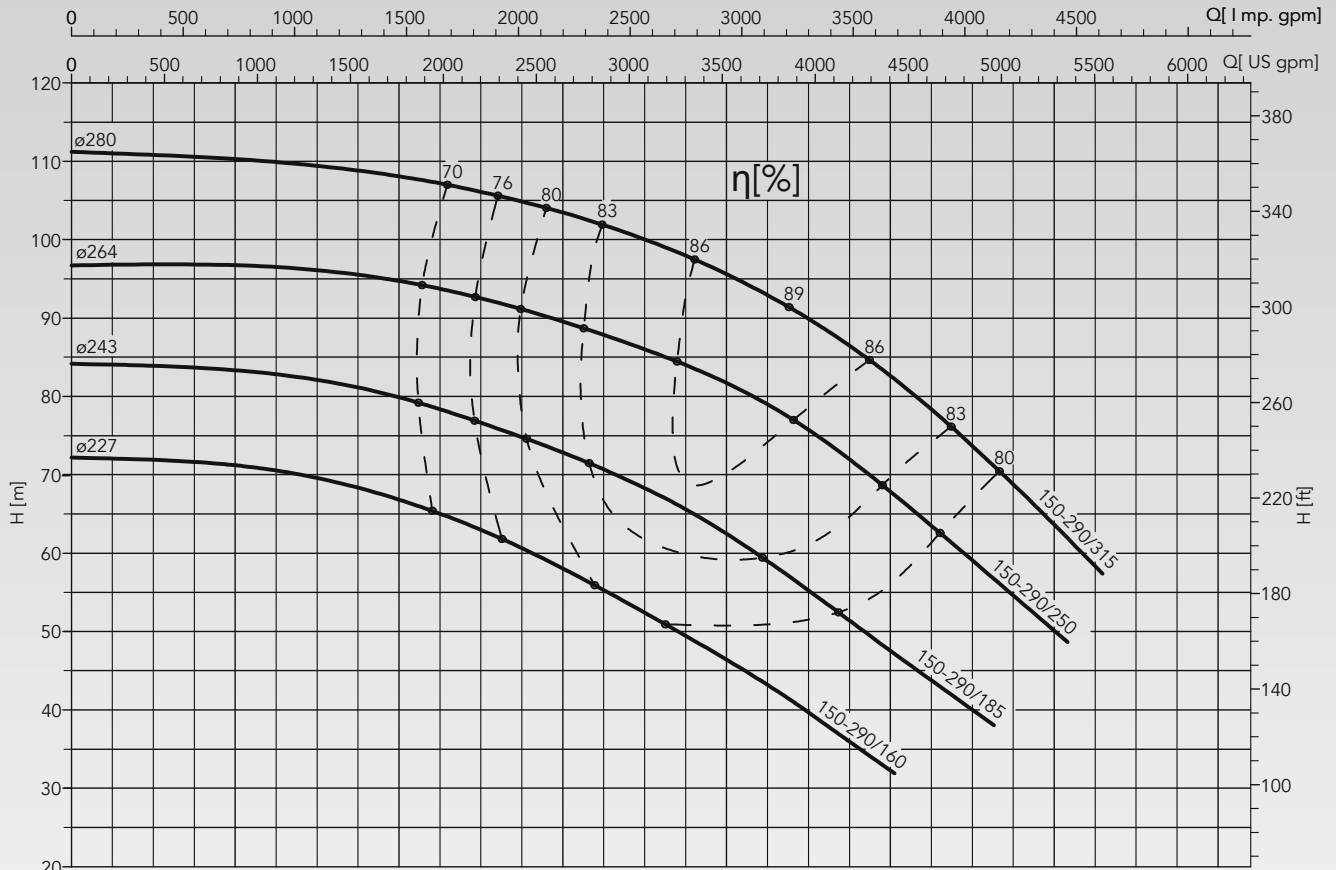

Pumps Dimensions and Weights

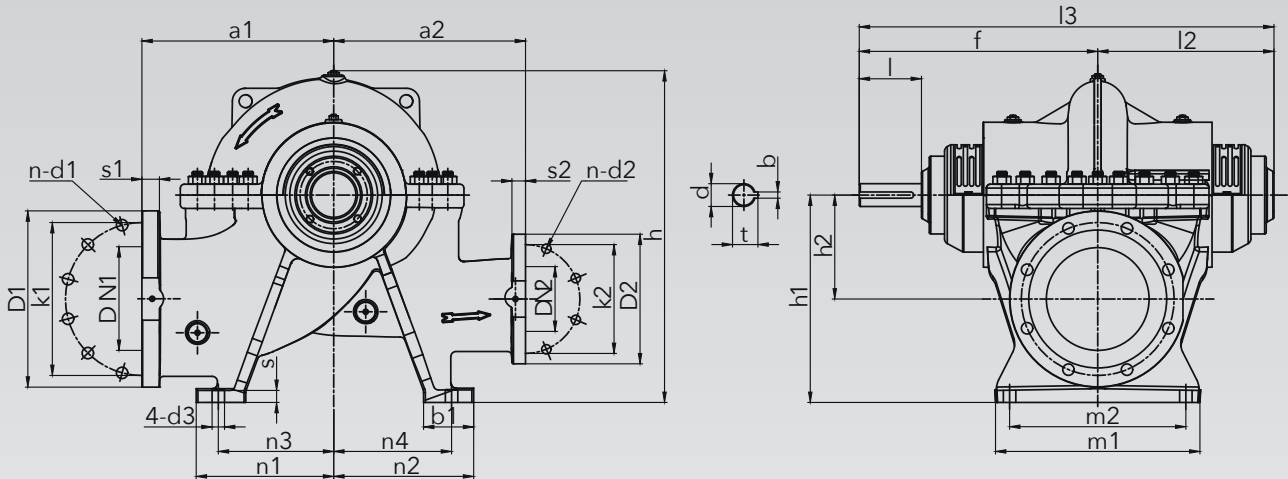

Type	DN1	DN2	a1	a2	f	l2	l3	h	h1	h2	m1	m2	n1	n2	n3	n4	b1	d3	s	d	b	l	t	kg
ESC 80 - 370	125	80	330	330	380	280	655	558	315	140	320	270	205	205	170	170	75	ø 24	23	ø 34	10	105	37,3	195
ESC 100 - 310G	150	100	330	330	380	300	685	605	355	170	320	270	235	235	200	200	80	ø 24	23	ø 39	12	105	42,3	213
ESC 100 - 375G	150	100	370	370	380	300	685	620	355	170	320	270	235	235	200	200	75	ø 24	23	ø 39	12	105	42,3	232
ESC 125 - 290	200	125	370	370	460	340	800	635	400	200	390	340	265	265	225	225	95	ø 24	23	ø 44	12	120	47,3	268
ESC 150 - 290	200	150	400	400	460	340	800	665	400	210	390	340	265	265	225	225	95	ø 24	23	ø 44	12	120	47,3	323
ESC 150 - 330	200	150	415	350	460	340	800	710	455	230	380	340	245	245	200	200	90	ø 24	23	ø 44	12	120	47,3	410

	ISO 7005 / DIN 2501 / PN16				DIN 2635 - PN40		CLASS 300 ANSI B16.5	
DN1 / DN2	100	125	150	200	80		150	
k1 / k2	180	210	240	295	160		269,7	
D1 / D2	235	250	285	340	200		317,5	
s1 / s2	26	26	26	30	24		36,6	
n-d1 / n-d2	8 - ø18	8 - ø18	8 - ø22	12 ø22	8 - ø18		12 - ø22	

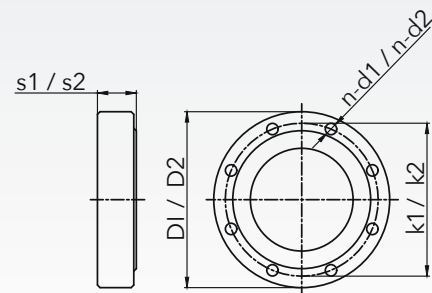

Exploded View for Mechanical Sealed Models

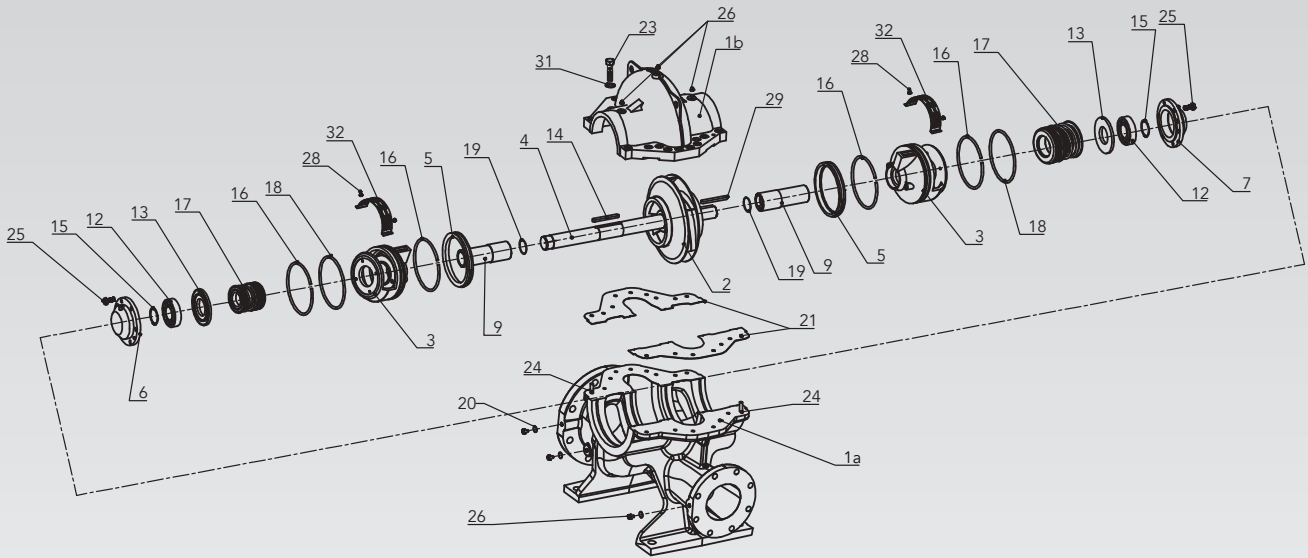

No	Part Name	Piece	Material
1a	Casing Lower Half	1	Gray Cast Iron / GG25
1b	Casing Upper Half	1	Gray Cast Iron / GG25
2	Impeller	1	Bronze / CuSn7
3	Cover Stuffing Box	2	Gray Cast Iron / GG25
4	Shaft	1	Stainless Stell / AISI 420
5	Casing Ring	2	Bronze / CuSn7
6	Housing Bearing Outboard	1	Gray Cast Iron / GG25
7	Housing Bearing Inboard	1	Gray Cast Iron / GG25
9	Seal - Shaft Seal	2	Bronze / CuSn7
12	Bearing	2	Refer to the Bearing Table
13	Bearing Seal Cover	2	KK-T NBR
14	Impeller Key	11	DIN 6885-Ç45K
15	Retaining Ring	2	DIN 471
16	Ring	4	AISI 304
17	Mechanical Seal	2	M106K / CE / EPDM / SUS304
18	O-Ring	2	NBR
19	O-Ring	2	NBR
20	O-Ring	7	NBR
21	Gasket Klingerit	2	t=1 mm
23	Bolt	14	DIN125A
24	Centring Pin	2	10.2
25	Bolt	8	10.2
26	Plug	7	G3/8"
28	Bolt	2	DIN125A
29	Motor Key	1	DIN 6885-Ç45K
31	Washer	14	DIN125A
32	Seal Guard Sheet	2	DIN 6885-A

Material	Part Name						
	GG25	GG40	CuSn7	CuSn10	AISI 420	AISI 316	AISI 304
Casing Lower Half	◆	◇					
Casing Upper Half	◆	◇					
Impeller	◇		◆	◇			
Shaft					◆	◇	◇

◆ Standard Product
◇ Optional Product

Exploded View for Soft Packing Models

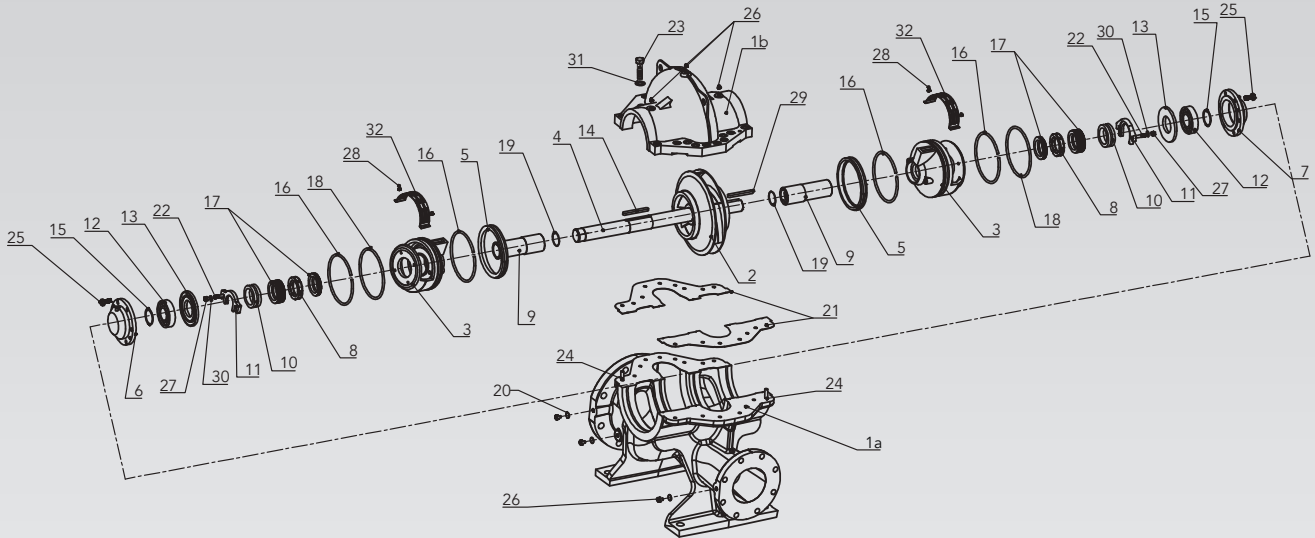

No	Part Name	Piece	Material
1a	Casing Lower Half	1	Gray Cast Iron / GG25
1b	Casing Upper Half	1	Gray Cast Iron / GG25
2	Impeller	1	Bronze / CuSn7
3	Cover Stuffing Box	2	Gray Cast Iron / GG25
4	Shaft	1	Stainless Stell / AISI 420
5	Casing Ring	2	Bronze / CuSn7
6	Housing Bearing Outboard	1	Gray Cast Iron / GG25
7	Housing Bearing Inboard	1	Gray Cast Iron / GG25
8	Lantern Ring	2	Bronze / CuSn7
9	Seal - Shaft Seal	2	Bronze / CuSn7
10	Gland	2	Bronze / CuSn7
11	Gland Holder	2	Gray Cast Iron / GG25
12	Bearing	2	Refer to the Bearing Table
13	Bearing Seal Cover	2	KK-T NBR
14	Impeller Key	11	DIN 6885-Ç45K
15	Retaining Ring	2	DIN 471
16	Ring	4	AISI 304
17	Packing	6	BURAFLOK
18	O-Ring	2	NBR
19	O-Ring	2	NBR
20	O-Ring	7	NBR
21	Gasket Klingerit	2	t=1 mm
22	Stud	4	10.2
23	Bolt	14	DIN125A
24	Centring Pin	2	10.2
25	Bolt	8	10.2
26	Plug	7	G3/8"
27	Nut	4	8
28	Bolt	2	DIN125A
29	Motor Key	1	DIN 6885-Ç45K
30	Washer	4	DIN125A
31	Washer	14	DIN125A
32	Seal Guard Sheet	2	DIN 6885-A

Material	Part Name						
	GG25	GGG40	CuSn7	CuSn10	AISI 420	AISI 316	AISI 304
Casing Lower Half	◆	◇					
Casing Upper Half	◆	◇					
Impeller	◇		◆	◇			
Shaft					◆	◇	◇

◆ Standard Product
◇ Optional Product

Assembly Drawing for Mechanical Sealed Models

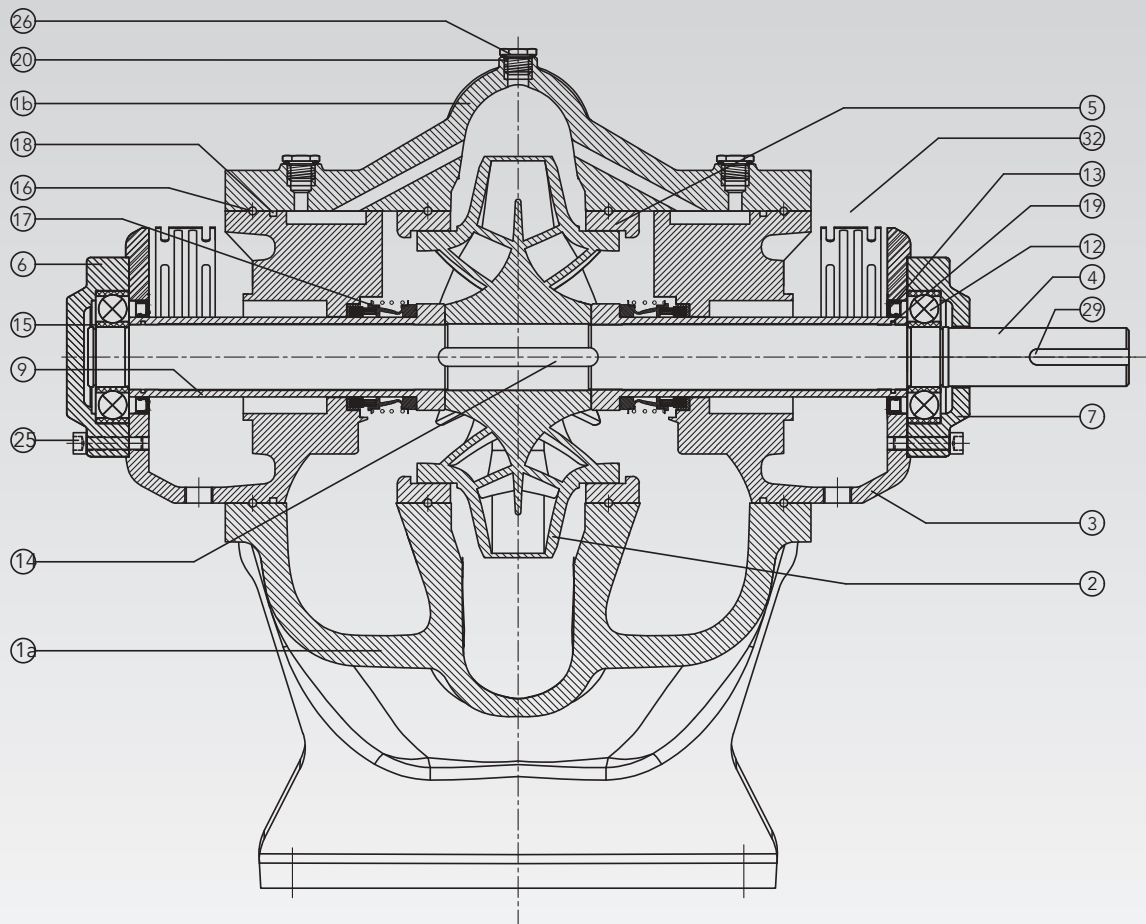

No	Part Name	No	Part Name
1a	Casing Lower Half	16	Ring
1b	Casing Upper Half	17	Packing
2	Impeller	18	O-Ring
3	Cover Stuffing Box	19	O-Ring
4	Shaft	20	O-Ring
5	Casing Ring	21	Gasket Klingerit
6	Housing Bearing Outboard	23	Bolt
7	Housing Bearing Inboard	24	Centring Pin
9	Seal Shaft Seal	25	Bolt
12	Bearing	26	Plug
13	Bearing Seal Cover	28	Nut
14	Impeller Key	29	Motor Key
15	Retaining Ring	32	Seal Guard Sheet

Assembly Drawing for Soft Packing Models

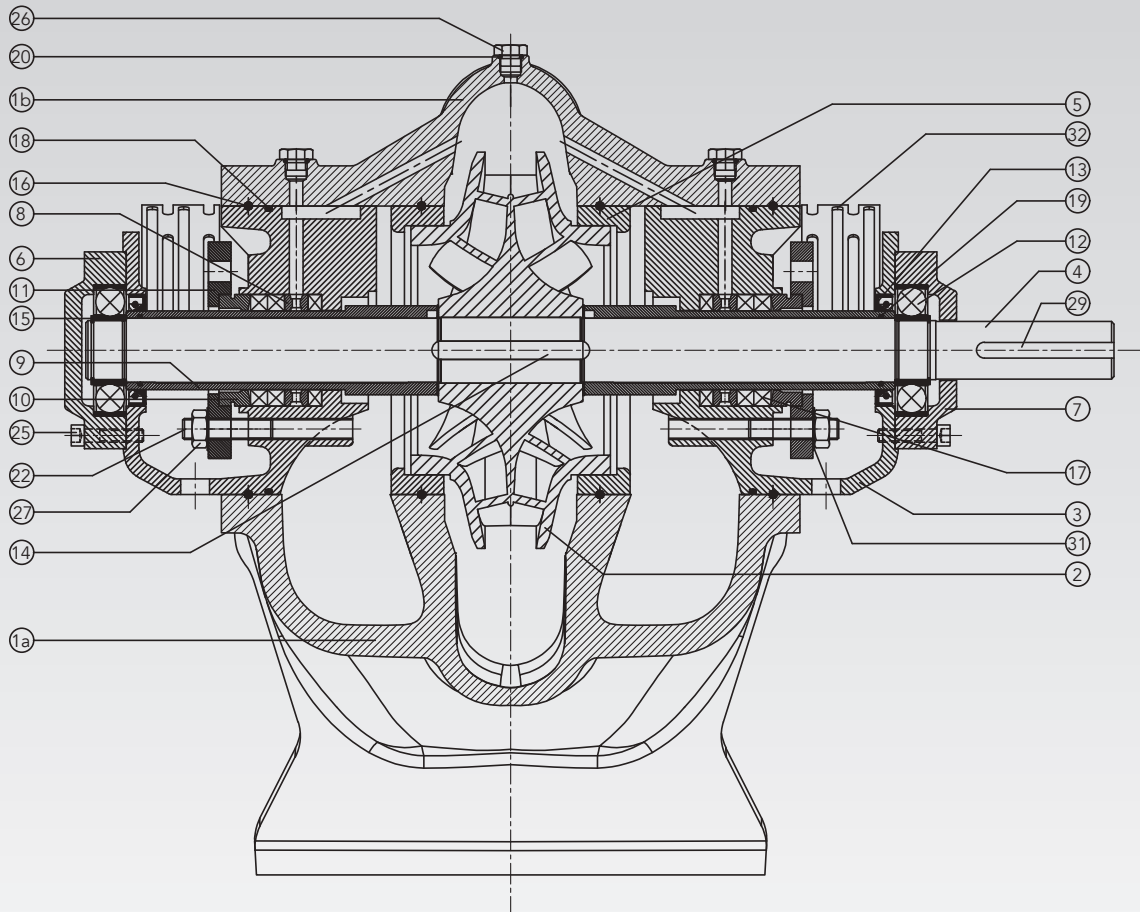

No	Part Name	No	Part Name
1a	Casing Lower Half	16	Ring
1b	Casing Upper Half	17	Packing
2	Impeller	18	O-Ring
3	Cover Stuffing Box	19	O-Ring
4	Shaft	20	O-Ring
5	Casing Ring	21	Gasket Klingerit
6	Housing Bearing Outboard	22	Stud
7	Housing Bearing Inboard	23	Bolt
8	Lantern Ring	24	Centring Pin
9	Seal - Shaft Seal	25	Bolt
10	Gland	26	Plug
11	Gland Holder	27	Nut
12	Bearing	28	Civata
13	Bearing Seal Cover	29	Motor Key
14	Impeller Key	31	Washer
15	Retaining Ring	32	Seal Guard Sheet

Technical Data for Mechanical Seal

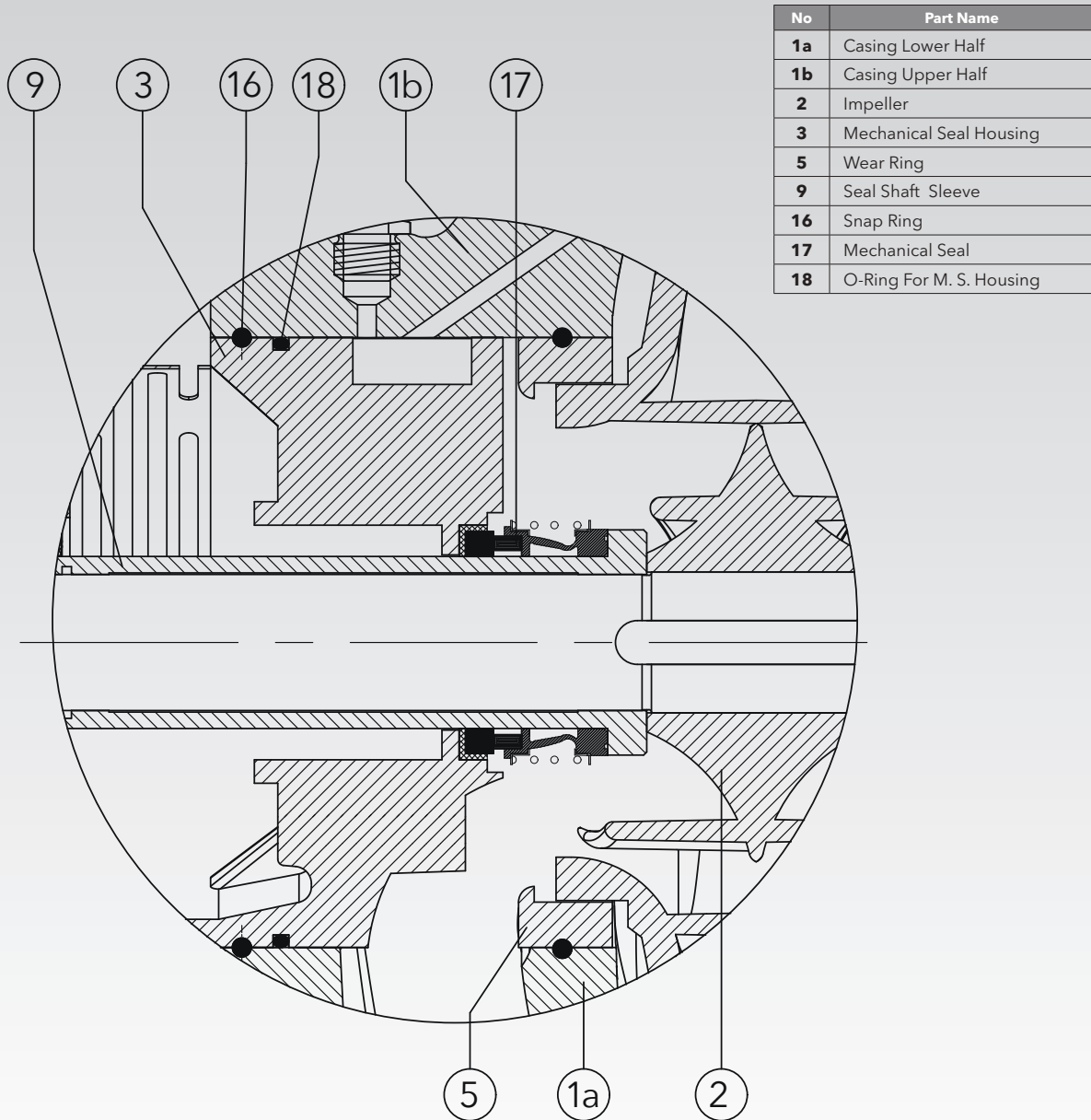

No	Part Name
1a	Casing Lower Half
1b	Casing Upper Half
2	Impeller
3	Mechanical Seal Housing
5	Wear Ring
9	Seal Shaft Sleeve
16	Snap Ring
17	Mechanical Seal
18	O-Ring For M. S. Housing

Type	Bearing (Motor Side)	Bearing (Dead Side)	Seal (Mechanical Seal)	Mechanical Seal Material
ESC 80 - 370	6308 (40x90x23)	6308 (40x90x23)	MG12-55	M106K / CE / EPDM / SUS304
ESC 100 - 310G	NU308 (40x90x23)	6308 (40x90x23)x2	MG12-55	M106K / CE / EPDM / SUS304
ESC 100 - 375G	NU308 (40x90x23)	6308 (40x90x23)x2	MG12-55	M106K / CE / EPDM / SUS304
ESC 125 - 290	6309 (45x100x25)	6309 (45x100x25)	MG12-60	M106K / CE / EPDM / SUS304
ESC 150 - 290	6309 (45x100x25)	6309 (45x100x25)	MG12-60	M106K / CE / EPDM / SUS304
ESC 150 - 330	6309 (45x100x25)	6309 (45x100x25)	MG12-60	M106K / CE / EPDM / SUS304

Technical Data for Soft Packing

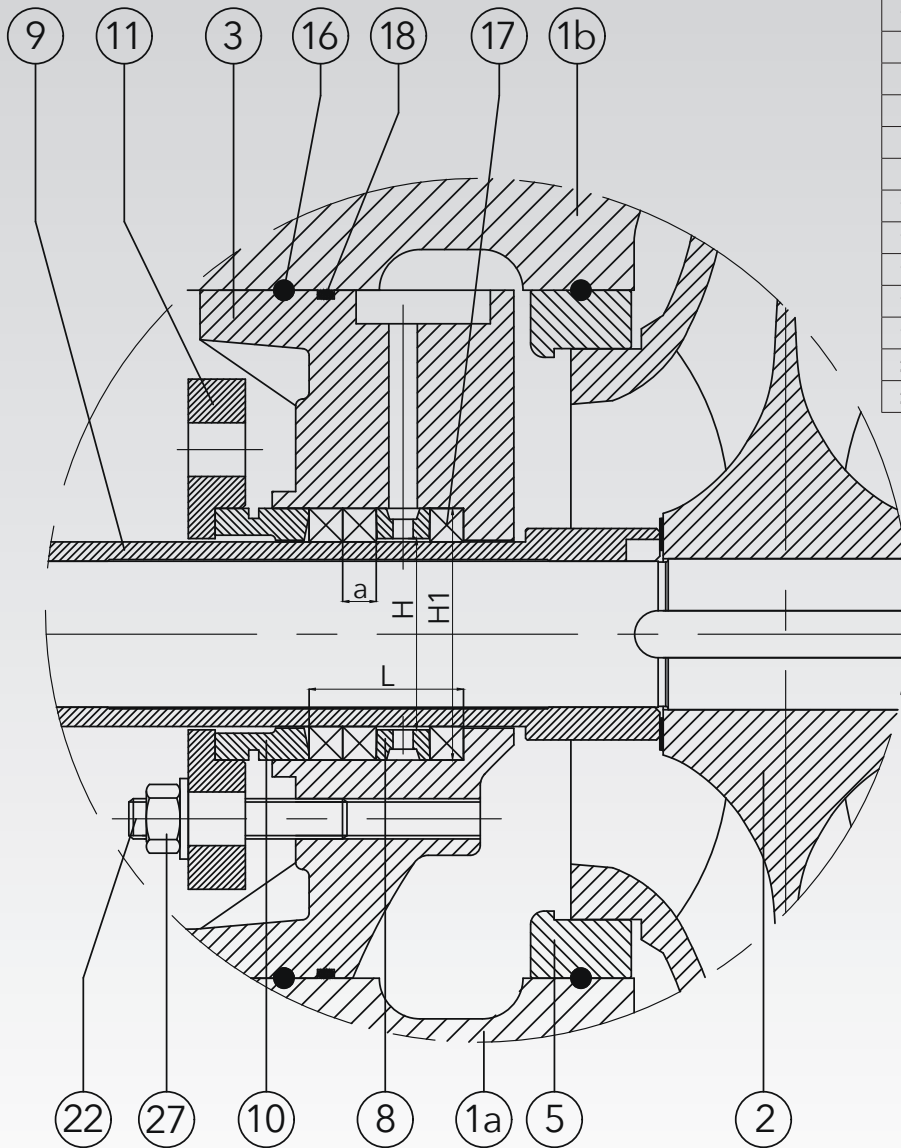

No	Part Name
1a	Casing Lower Half
1b	Casing Upper Half
2	Impeller
3	Stuffing Box / Packing Seal
5	Wear Ring
8	Lantern Ring
9	Seal Shaft Sleeve
10	Gland
11	Gland Bracket
16	Snap Ring
17	Packing Seal
18	O-Ring For Stuffing Box
22	Stud
27	Nut

Type	Bearing (Motor Side)	Bearing (Dead Side)	Seal (Soft Packing) (H1xHxaxL)mm	Sealing
ESC 80 - 370	6308 (40x90x23)	6308 (40x90x23)	Ø75xØ55x12x65	2x (4 Soft Packing + 1 Lantern Ring)
ESC 100 - 310G	NU308 (40x90x23)	6308 (40x90x23)x2	Ø75xØ55x12x65	2x (4 Soft Packing + 1 Lantern Ring)
ESC 100 - 375G	NU308 (40x90x23)	6308 (40x90x23)x2	Ø75xØ55x12x65	2x (4 Soft Packing + 1 Lantern Ring)
ESC 125 - 290	6309 (45x100x25)	6309 (45x100x25)	Ø85xØ60x12x70	2x (4 Soft Packing + 1 Lantern Ring)
ESC 150 - 290	6309 (45x100x25)	6309 (45x100x25)	Ø85xØ60x12x70	2x (4 Soft Packing + 1 Lantern Ring)
ESC 150 - 330	6309 (45x100x25)	6309 (45x100x25)	Ø85xØ60x12x70	2x (4 Soft Packing + 1 Lantern Ring)

Installation Types

PUMP INSTALLATION WITH DIESEL

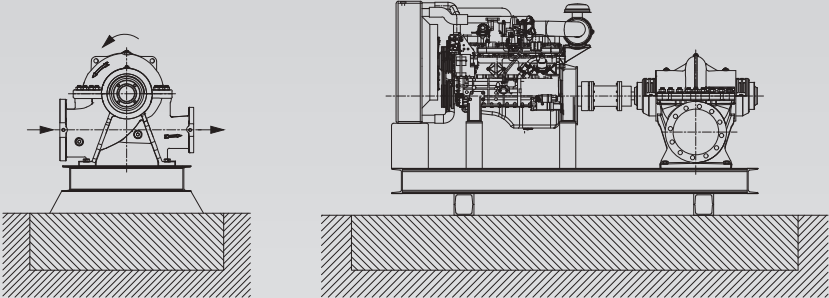

PUMP INSTALLATION WITH ELECTRIC MOTOR

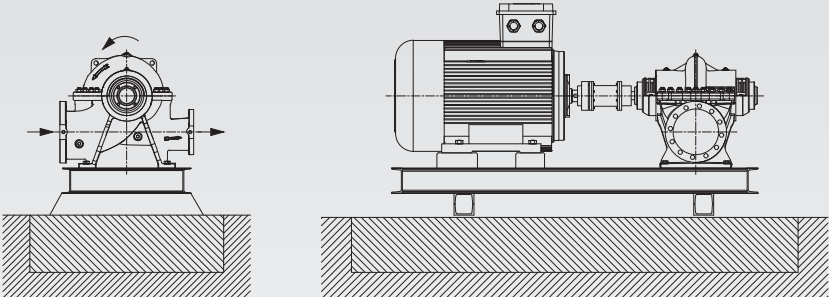

DIRECTION OF ROTATION AND FLOW

Direction of rotation clockwise
(Motor from the drive end)

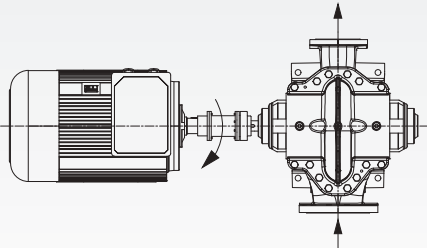

Direction of rotation counter clockwise
(Motor from the drive end)

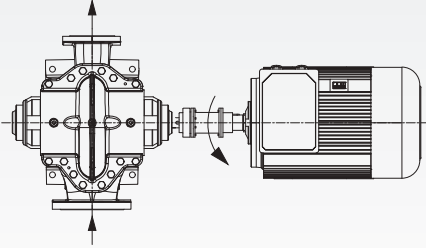

Direction of rotation counter clockwise
(Motor from the drive end)

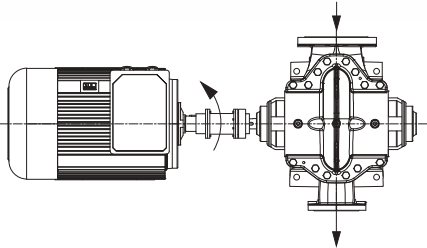

Direction of rotation clockwise
(Motor from the drive end)

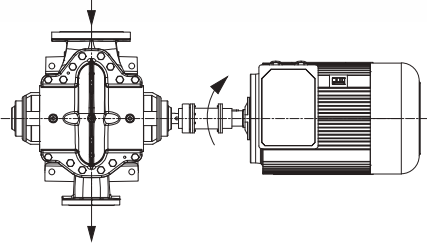

Notes

Rev 02/2025



Dudullu Organize Sanayi Bölgesi 2. Cadde No: 14
34775 Ümraniye - İstanbul / Turkey
Tel : +90 216 561 47 74 (Pbx) • Fax : +90 216 561 47 50
www.etna.com.tr/en • info@etna.com.tr



ETNA®

0850 455 38 62
customer service