



ECP-F Modbus Registry List

Record Of Changes

Version Number	Changes
V0.0.1	Formulate
V0.0.2	2023.8.22 Remove 0xff function code description. 1. Add 0x10 function code 2. Add detailed register descriptions.
V0.0.3	2023.9.25 1. Add description of fault relay with external digital input. 2. Add configuration word description for device_config.
V0.0.4	1. Add a description of the external interface.
V0.0.5	2. 2023.12.12 Description when adding external IO control.

1. Modbus Communication Protocol

This protocol is based on the MODBUS-RTU protocol ("Remote Terminal Unit" mode) to realize remote control of hot water circulation pump equipment..

1.1 UART Configuration

1.1.1 One Start Bit, 8 Data Bits, Low First;

Start (low)	Bit0 (LSB)	Bit1	Bit2	Bit3	Bit4	Bit5	Bit6	Bit7	Parity	Stop (high)

1.1.2 Baud Rate: 115200bps

1.1.3 Parity Bit: None, No parity (factory default);

1.1.4 Stop Bit: 1bit (default)

The slave communication configuration can be changed at the initiative of the master after communication is established. Refer to 1.5 Corresponding Register Information and 1.5.4 Command Examples for details.

1.2 Communications Protocol

1.2.1 Adopt master-slave mode, all communication must be initiated by the master and answered by the slave. Supports single master-slave mode with fixed slave address 0x01.

1.2.2 Only the master is authorised to initiate communication, and the slave replies only after receiving a legitimate and complete command from the master.

1.2.3 The host should be continuous in sending data, with no interval or intervals of <1.5 bytes of time between bytes.

1.2.4 The slave starts replying at least 50ms after receiving a command from the master.

1.2.5 The slave should be continuous in sending data, with no interval or intervals of <1.5 bytes of time between bytes.

1.2.6 If the host does not respond after sending a frame of command, it will retry every 200ms. If the communication cannot be carried out normally for a long time, the host should deal with it accordingly.

1.2.7 If the slave does not receive a valid command for a long period of time, the slave will also be processed accordingly.

1.3 Protocol Frame

Host to Slave:

address code (8bit)	command code (8bit)	numbers (N*8bit)	CRCL (8bit)	CRCH (8bit)
----------------------------	----------------------------	-------------------------	--------------------	--------------------

Slave to Host:

address code (8bit)	command code (8bit)	numbers (N*8bit)	CRCL (8bit)	CRCH (8bit)
----------------------------	----------------------------	-------------------------	--------------------	--------------------

1.3.1 Slave Address

Each slave has its own 8-bit address. The factory default address for hot water circulation pumps is 0x01. Slave addresses cannot be duplicated on the same network. With the exception of the broadcast address, a slave only acknowledges and responds to messages with the same ID as itself. The communication protocol defines a broadcast address: 0xFF.

Slave Address	Command
0x01 to 0xF7	Execute the instruction only when the slave address (1-247) corresponds and reply to the master.

Coding	Command
0x03	Read Holding Register
0x04	Read Input Register
0x06	Write Single Register
0x10	Write multiple registers

1.3.2 Supported Command Codes

1.3.3 Numbers

The data word definitions for the different commands are different, see Section 5.4 UART Commands for details and Section 5.5 Register Value Ranges.

1.3.4 CRC Calibration

Redundant cyclic code CRC16 (MODBUS) containing 2 bytes, sent with the low byte first and the high byte second.

1.4 UART Commands Explained

1.4.1 Command Code = 0x03 (Read Holding Register)

Host to Slave:

Slave address (1 byte)	Command code (0x03)	First Holding Register Address (2) bytes, high byte first	Registers read Number (2 bytes)	Checksum CRC (2 bytes)
---------------------------	------------------------	---	------------------------------------	---------------------------

Slave to Host (Reply):

Slave address (1 byte)	Command code (0x03)	Total data bytes Number (1 byte)	First register data	Nth register data	CRC calibration (2 bytes)
---------------------------	------------------------	-------------------------------------	------------------------	----------------------	------------------------------

1.4.2 Command Code = 0x04 (Read Input Register)

Host to Slave:

Slave address (1 byte)	Command code (0x04)	Input register start address (2) bytes, high byte first	Registers read Number (2 bytes)	Checksum CRC (2 bytes)
---------------------------	------------------------	---	------------------------------------	---------------------------

Slave to Host (Reply):

Slave address (1 byte)	Command code (0x04)	Total data bytes Number (1 byte)	First host data storage	(b) (a) The N. N register data	CRC calibration (2 bytes)
---------------------------	------------------------	-------------------------------------	----------------------------	-----------------------------------	------------------------------

1.4.3 Command Code = 0x06 (Write Single Holding Register)

Host to Slave:

Slave address (1 byte)	Command code (0x06)	Holding register address (2 words) section, high byte first	Write register value (2 words) section, high byte first	Checksum CRC (2 bytes)
---------------------------	------------------------	---	---	---------------------------

Slave to Host (Reply):

Slave address (1 byte)	Command code (0x06)	Holding register address (2 words) section, high byte first	Write register value (2 words) section, high byte first	Checksum CRC (2 bytes)
---------------------------	------------------------	---	---	---------------------------

slave address (1 byte)	Command code (0x04)	Total data bytes Number (1 byte)	First post data storage	(b) (a) The N. N register data	CRC calibration (2 bytes)
---------------------------	------------------------	-------------------------------------	----------------------------	-----------------------------------	------------------------------

1.4.4 Exception Code

In the case of an error, the slave will send only one data byte (exception code)

0x01: Unsupported command.

0x02: Holding register address is out of range.

1.5 Register List

1.5.1 Input Register List - Read Only (Do not use if not)

Address	Register Name	Define	Range Of Values	Registers Interntional Address (Hexadecimal)	Note
I0	control_version	MCE version	-	0x0600	16-Bit, Unsigned
I1	now_speed_i	Real-time RPM	1200~4200	0x0601	Unit: Rpm
I2	igbt_vth	igbt temperature		0x0602	
I3	input_frequence	Input frequency		0x0603	1 for 0.1hz
I4	input_voltage	Input Voltage		0x0604	
I5	flt_input_power	input power		0x0605	Unit: W
I6	motor_temp	Motor temperature		0x0606	Unit: Degrees Celsius
I7	run_status	boot-up state	0~4	0x0607	0: stop 1: running 2: constant speed (minimum) 3: constant speed (max.) 4: malfunction
I8	device_status	Equipment operating status	-	0x0608	BIT0: Whether to enter power limit Rate mode (1~yes; 0~no) BIT1: whether to enter night mode (1~yes; 0~no)
I9	Sense_mA_1	4-20mA electrical Sampling of streams	-	0x0609	22mA max. 1mA corresponds to 186.18 count value. Maximum 4095 counts

Address	Register Name	Define	Range Of Values	Registers Interntional Address (Hexadecimal)	Note
I10	Sense_mA_2	4-20mA electrical Sampling of streams	-	0x060a	22mA max. 1mA corresponds to 186.18 count value Maximum 4095 counts
I9	fault_flag	trouble signal	-	0x060B	See 5.5.3
I10	flow_rt_ft	Display-Flow	-	0x060C	16384 indicates 50m ³
I11	head_rt_ft	Display - Lift	-	0x060D	16384 means 15m
	vsp	Analogue input voltage	-	0x060E	Maximum 4095. 4095 for 12.49V
I12	Energy_consumption	Total power low	-	0x060F	1 denotes 0.001kwh
I13	Energy_consumption1	Total power high	-	0x0610	1 denotes 0.001kwh
I14	Running_hours	Cumulative running hours lows	-	0x0611	Lower 16 bits ins
I15	Running_hours1	Cumulative running hours a high (i.e. local maximum)	-	0x0612	High 16 full, units
	Input_io	Input IO port detection conjecture	-	0x0614	1:high 0:low
I16	limit_power_run	Actual operating limit rate point	-	0x0615	2048 indicates 260.94W
I17	default_rpm_limit	Default limit of rotation speed fix the scope	-	0x0616	Default value: 10764
I18	default_flow_limit	Default limits of flowfix the scope	-	0x0617	Default value: 8448
I19	default_head_limit	Default limit of pressure fix the scope	-	0x0618	Default value: 3074

Address	Register Name	Define	Range Of Values	Registers Interntional Address (Hexadecimal)	Note
I20	Rtc	RTC Clock	-	0x0619	Real-time timestamps 64-bit medium-low 16-bit
I21	Rtc1	RTC Clock	-	0x061A	Real-time timestamps in low 64-bit 17-32 bit
I22	Rtc2	RTC Clock	-	0x061B	Real-time timestamps in low 64-bit 33-48 bits
I23	Rtc3	RTC Clock	-	0x061C	Real-time timestamp low-high 64-bit 16-bit

1.5.2 Holding Registers - Read/Write (Do not use if not listed)

Address	Register Name	Define	Range Of Values	Registers Interntional Address (Hexadecimal)	Note
H0	set_speed_i	Setting speed	1200~4200	0x061E	-
H1	run	power-on	0~3	0x061F	0: Stop 1: Running 2: Constant speed (minimum) 3: Constant speed (maximum)
H2	slave_address	slave	1~247	0x0620	Default 1
H3	set_flow	Setting flow rate	-	0x0621	16384 indicates
H4	set_head	Setting head	-	0x0622	16384 means 15m
H5	fault_clear	Clearing fault	0~1	0x0623	0: default 1: Clearance

Address	Register Name	Define	Range Of Values	Registers Interntional Address (Hexadecimal)	Note
H6	mode_config	operating	0~7	0x0624	0: Adaptive 1: Flow adaptive 2: proportional pressure 3: constant pressure 4: constant speed 5: constant temperature 6: Temperature difference 7: constant current
H8	device_config	Equipment Configuration	1 to 8	0x0626	BIT0: Night mode BIT1: Remote control BIT2: Internal power control
H9	set_pro_pressure	Set pressure (at proportional pressure) strength value	2~12	0x0627	16384 means 15m
H10	set_const_temperature	Setting at constant temperature temperature value	-	0x0628	16384 means 200 degrees
H11	set_diff_temperature	Temperature difference time setting temperature value	-	0x0629	16384 means 200 degrees
H12	default_set	Restore default settings	0~0xAAAA	0x062A	0: Normal 0xAAAA: Restore default settings
H13	auto_adapt_min_head	adaptive most Small head value	1638~16384	0x062B	16384 means 15m
H14	set_ulBaudRate	Baud rate for modbus communication	0~2	0x062C	0: 9600 1: 19200 2: 115200 Default: 115200

Address	Register Name	Define	Range Of Values	Registers Interntional Address (Hexadecimal)	Note
H15	night_time_start_time	Night mode start time	0-1440	0x062D	Number of minutes in a day that night mode starts - e.g. 01:00 Starting at 60
H16	night_time_end_time	Night mode end time	0-1440	0x062E	Number of minutes in a day when night mode ends - e.g. 02:00 End, then 120
H17	Dout	Relay digital exports	0-1	0x0633	1: Closure 0: Disconnected

1.5.3 Detailed Description

The functions of some registers may change due to product software updates. Please contact factory support if you have any problems with use.

Control Version

Address	s0x0600		
Unit	None		
Variable Type	Read		
Range	Min:0	Max:65535	Default.

Description: The high 8-digit H stands for Major, the middle 5-digit M stands for Minor, and the low 3-digit L stands for Revision.

15	14	13	12	11	10	9	8	7	6	5	4	3	2	1	0
H	H	H	H	H	H	H	H	M	M	M	M	M	L	L	L

Now Speed I

Address	0x0601		
Unit	RPM		
Variable Type	Read		
Range	Min:0	Max:65535	Default.

Description: The real-time speed of the water pump.

igbt_vth

Address	0x0602		
Unit	°C		
Variable Type	Read		
Range	Min:0	Max:110	Default.

Description: Detected temperature value inside the power module IGBT in the water pump.

Input Frequency

Address	0x0603		
Unit	Hz		
Variable Type	Read		
Range	Min.	Max.	Default.

Description: Frequency of real-time AC input for water pump.
(Operating frequency 40-70Hz)

igbt_vth

Address	0x0602		
Unit	°C		
Variable Type	Read		
Range	Min:0	Max:110	Default.

Description: Detected temperature value inside the power module IGBT in the water pump.

Input Voltage

Address	0x0604		
Unit	V		
Variable Type	Read		
Range	Min.	Max.	Default.

Description: RMS voltage of real-time input AC for water pump.

flt_input_power

Address	0x0605		
Unit	W		
Variable Type	Read		
Range	Min.	Max.	Default.

Description: The real-time input power of the water pump.

Run Status

Address	0x0607		
Unit	None		
Variable Type	Read		
Range	Min:0	Max:4	Default.

Description: The operating status of the water pump.

- 0:** Stop
- 1:** Normal
- 2:** Max_Speed in Const_Speed mode
- 3:** Min_Speed in Const_Speed mode
- 4:** Fault

Device Status

Address	0x0608		
Unit	None		
Variable Type	Read		
Range	Min:0	Max:2	Default.

Description: Parsing by bit.

15	14	13	12	11	10	9	8	7	6	5	4	3	2	1	0
N	N	N	N	N	N	N	N	N	N	N	N	N	N	Bit1	Bit0

Bit0: Whether to enter the power limit state
(the pump is limited by the internal maximum power)

Bit1: Whether to enter the night mode

Sense MA 1

Address	0x0609		
Unit	mA		
Variable Type	Read		
Range	Min:0	Max:4095	Default.

Description: Detected value of external terminal T1 of water pump.

1mA corresponds to 186.18.

Value/4096*22mA = Final input valuepump.

Sense MA 2

Address	0x060A		
Unit	mA		
Variable Type	Read		
Range	Min:0	Max:4095	Default.

Description: Measured value of external terminal T2 of water pump.

1mA corresponds to 186.18.

Calculation Formula= Value/4096*22 mA

Fault Flag

Address	0x060B		
Unit	None		
Variable Type	Read		
Range	Min:0	Max:65535	Default.

Description: Parsing by bit, characterising the meaning of different faults.

15	14	13	12	11	10	9	8	7	6	5	4	3	2	1	0
Bit15	Bit14	Bit13	Bit12	Bit11	Bit10	Bit9	Bit8	Bit7	Bit6	Bit5	Bit4	Bit3	Bit2	Bit1	Bit0

- | | |
|---|--|
| Bit0: Internal drive overcurrent | Bit8: Pump out of phase |
| Bit1: Reserve | Bit9: Reserve |
| Bit2: Internal bus overvoltage fault | Bit10: Reserve |
| Bit3: Internal bus undervoltage fault | Bit11: Input frequency fault |
| Bit4: Motor runaway fault - stall | Bit12: Internal memory failure |
| Bit5: Water shortage fault | Bit13: Internal communication failure |
| Bit6: Internal IGBT temperature too high | Bit14: Input AC undervoltage |
| Bit7: Pump blocking | Bit15: Input AC overvoltage |

igbt_vth

Address	0x0602		
Unit	°C		
Variable Type	Read		
Range	Min:0	Max:110	Default.

Description: Detected temperature value inside the power module IGBT in the water pump.

Flow Rt Flt

Address	0x060C		
Unit	m ³ /h		
Variable Type	Read		
Range	Min:0	Max:65535	Default.

Description: Real-time flow rate value of a water pump.

Calculation Formula: Value/16384*50 m³ /h

Head Rt Flt

Address	0x060D		
Unit	m		
Variable Type	Read		
Range	Min:0	Max:65535	Default.

Description: The real-time head value of a water pump.

Calculation Formula: Value/16384*15 m

Vsp

Address	0x060E		
Unit	V		
Variable Type	Read		
Range	Min:0	Max:4095	Default.

Description: Real time vsp voltage of water pump.

Calculation Formula= Value/4096*12.49 V

Energy Consumption

Address	0x060F		
Unit	K-W/h		
Variable Type	Read		
Range	Min:0	Max:65535	Default.

Description: The real time energy consumption of a water pump needs to be calculated by splicing it with Energy_consumption1 and automatically recorded when power is lost.

Calculation Formula= (Energy_consumption + Energy_consumption1 * 65536)*0.001 K-W/h

Energy Consumption1

Address	0x0610		
Unit	K-W/h		
Variable Type	Read		
Range	Min:0	Max:65535	Default.

Description: The real time energy consumption of the water pump needs to be calculated by splicing it with Energy_consumption, which is automatically logged when the power is turned off.

Calculation Formula= (Energy_consumption + Energy_consumption1 * 65536)*0.001 K-W/hK-W/h

Running Hours

Address	0x0611		
Unit	s		
Variable Type	Read		
Range	Min:0	Max:65535	Default.

Description: Accumulated running hours of the water pump, recording the total running hours except fault and shutdown modes, and the total running hours with Running_hours1 Splice calculation, power-down logging.

Calculation Formula= (Running_hours + Running_hours1 * 65536) s

Running Hours1

Address	0x0612		
Unit	s		
Variable Type	Read		
Range	Min:0	Max:65535	Default.

Description: Accumulated running hours of the water pump, recording the total running hours except fault and shutdown modes, and the total running hours with Running_hours1 Splice calculation, power-down logging.

Calculation Formula= (Running_hours + Running_hours1 * 65536) s

Input_io

Address	0x0614		
Unit	None		
Variable Type	Read		
Range	Min:0	Max: 1	Default.

Description: Din on the wiring terminal.

0: Input low level

1: Input high level

Limit Power Run

Address	0x0615		
Unit	W		
Variable Type	Read		
Range	Min:0	Max:110	Default.

Description: Real-time limited power value of water pump.

Calculation Formula= Value/2048*260.94 W

Default Rpm Limit

Address	0x0616		
Unit	RPM		
Variable Type	Read		
Range	Min.	Max.	Default.

15	14	13	12	11	10	9	8	7	6	5	4	3	2	1	0
H	H	H	H	H	H	H	H	L	L	L	L	L	L	L	L

Description: The value of the maximum and minimum speed of the water pump.

Calculation Formula=

Minimum speed = L * 100 RPM

Maximum speed = H * 100 RPM

Default Flow Limit

Address	0x0617		
Unit	m3/h		
Variable Type	Read		
Range	Min.	Max.	Default.

15	14	13	12	11	10	9	8	7	6	5	4	3	2	1	0
H	H	H	H	H	H	H	H	L	L	L	L	L	L	L	L

Description: The value of the maximum and minimum speed of the water pump.

Calculation Formula=

Minimum flow = L m³/h

Maximum flow rate = H m³ /h

Default Head Limit

Address	0x0618		
Unit	m		
Variable Type	Read		
Range	Min.	Max.	Default.

15	14	13	12	11	10	9	8	7	6	5	4	3	2	1	0
A	A	A	A	A	B	B	B	C	C	C	C	C	D	D	D

Description: The minimum and maximum values of the set head of the water pump

Calculation Formula=

- Maximum head setting for proportional pressure = A m
- Maximum head setting for proportional pressure = B m
- Maximum head setting for constant pressure = C m
- Minimum head setting for constant pressure = D m

Rtc

Address	0x0619		
Unit	s		
Variable Type	Read		
Range	Min:0	Max:65535	Default.

Description: Internal RTC clock of the water pump, need to splice the calculation, RTC refresh is not strictly by s.

Calculation Formula= $Rtc + Rtc1 * 65536 + Rtc2 * 65536 + Rtc3 * 65536$ s

Rtc1

Address	0x061A		
Unit	s		
Variable Type	Read		
Range	Min:0	Max:65535	Default.

Description: Internal RTC clock of the water pump, need to splice the calculation, RTC refresh is not strictly by s.

Calculation Formula= $Rtc + Rtc1 * 65536 + Rtc2 * 65536 + Rtc3 * 65536$ s

Rtc2

Address	0x061B		
Unit	°C		
Variable Type	Read		
Range	Min:0	Max:65535	Default.

Description: Internal RTC clock of the water pump, need to splice the calculation, RTC refresh is not strictly by s.

Calculation Formula= $Rtc + Rtc1 * 65536 + Rtc2 * 65536 + Rtc3 * 65536$ s

Rtc3

Address	0x061C		
Unit	°C		
Variable Type	Read		
Range	Min:0	Max:65535	Default.

Description: Internal RTC clock of the water pump, need to splice the calculation, RTC refresh is not strictly by s.

Calculation Formula= $Rtc + Rtc1 * 65536 + Rtc2 * 65536 + Rtc3 * 65536$ s

set_speed_i

Address	0x061E		
Unit	RPM		
Variable Type	Read Write		
Range	Min:0	Max:65535	Default:1200

Description: The set speed value in RPM in constant speed mode.

Run

Address	0x061F		
Unit	None		
Variable Type	Read Write		
Range	Min:0	Max:3	Default:1

Description: The command to switch on/off the water pump.

0: Stop

1: Normal

2: Max_Speed in Const_Speed mode

3: Min_Speed in Const_Speed mode

Slave Address

Address	0x0620		
Unit	None		
Variable Type	Read Write		
Range	Min:0	Max:247	Default:1

Description: The address of the water pump as a Modbus slave. Modify the address, and it will take effect after re-powering up.

Set Flow

Address	0x0621		
Unit	m3/h		
Variable Type	Read Write		
Range	Min:0.25 * nominal maximum flow rate	Max:0.95 * nominal maximum flow rate	Default:0.55 * nominal maximum flow rate

Description: Default limited flow value for pump flow adaptation, default is 55% of the maximum flow.

Formula = Value / 16384 * 50 m³ /h

Set Head

Address	0x0622		
Unit	m		
Variable Type	Read Write		
Range	Min:Minimum setting value of nominal spring range	Max:Nominal head	Default:0.55 * Nominal Population Range

Description: Set head value for constant head of the pump, default is 55% of the maximum head.

Calculation Formula= Value / 16384 *15 m

Fault Clear

Address	0x0623		
Unit	None		
Variable Type	Read Write		
Range	Min:0	Max:1	Default.

Description: When writing 1, tries to clear all faults of the current pump. After clearing, the pump automatically returns to 0, if the faults no longer exist. If the fault no longer exists, then the pump will automatically return to the previous operating state from the fault state. If the fault still exists, the pump still displays the current fault.

Mode Config

Address	0x0624		
Unit	None		
Variable Type	Read Write		
Range	Min:0	Max:7	Default.

Description: The operating mode of the water pump.

- | | |
|---------------------------------|--------------------------|
| 0: Adaptive | 4: Constant speed |
| 1: Flow adaptive | 5: Reserve |
| 2: Proportional pressure | 6: Reserve |
| 3: Constant pressure | 7: Reserve |

Device Config

Address	0x0626		
Unit	None		
Variable Type	Read Write		
Range	Min:0	Max:1	Default:0

Description: Control by bit, if the bit is 1, it means this function is effective.

Bit0: Night mode

Bit1: Reserved must be 0.

Bit2: Reserved must be 0.

Bit3: Reserved must be 0.

Bit4: External IO Control device start/stop

Bit5: Output relay represents the fault status of the device.

Set Pro Pressure

Address	0x0627		
Unit	m		
Variable Type	Read Write		
Range	Min:0	Max:Nominal Maximum Lift	Default:0.55 * Nominal Head

Description: Maximum pressure value for the proportional pressure mode of the pump, default is 55% of the maximum head.

Calculation Formula= Value / 16384 *15 m

Default Set

Address	0x062A		
Unit	None		
Variable Type	Read Write		
Range	Min:0	Max:0xAAAA	Default:0

Description: Write 0xAAAA to restore the default factory configuration of the pump. After writing 0xAAAA, this register will be restored to 0 automatically after the pump performs the corresponding operation.

Auto Adapt Min Head

Address	0x062B		
Unit	m		
Variable Type	Read Write		
Range	Min:1638	Max:Nominal Head	Default:1638

Description: Minimum head value for pump adaptive mode, default is 1.5m head.

Calculation Formula= Value / 16384 *15 m

Setflow

Address	0x0621		
Unit	m ³ /h		
Variable Type	Read Write		
Range	Min:0	Max:65535	Default.

Description: Default limited flow value for pump flow adaptation, default is 55% of the maximum flow.

Calculation Formula= Value / 16384 *50 m³ /h

Set UIBaudRate

Address	0x062C		
Unit	None		
Variable Type	Read Write		
Range	Min:0	Max:2	Default:2

Description: Default baud rate of RS485 when the water pump is working. Other configurations are no parity, 1 bit stop bit.

0: 9600

1: 19200

2: 115200

Night Time Start Time

Address	0x062D		
Unit	min		
Variable Type	Read Write		
Range	Min:0	Max:1440	Default:1380

Description: The time when the water pump will switch on the night mode, default is 23*60 which means it will enter the night mode at 23 o'clock. This function will only work if you switch on the bit0 night mode function in device_config. In night mode, the maximum power is reduced to 50W.

Calculation Formula= Value / 60

Night Time End Time

Address	0x062E		
Unit	Min		
Variable Type	Read Write		
Range	Min:0	Max:1440	Default:420

Description: The time when the water pump will switch on the night mode, by default it is 7*60 which means it will exit the night mode at 7 o'clock. This function will only take effect if the bit0 night mode function in device_config is turned on. In night mode, the maximum power is reduced to 50W.

Calculation Formula= Value / 60

Dout

Address	0x0633		
Unit	None		
Variable Type	Read Write		
Range	Min:0	Max:1	Default:0

Description: Function of the relay between Y0 and COM on the input/output terminals of the water pump. When 1 is written, it is closed, and when 0 is written, it is disconnected.

2. Interface Description

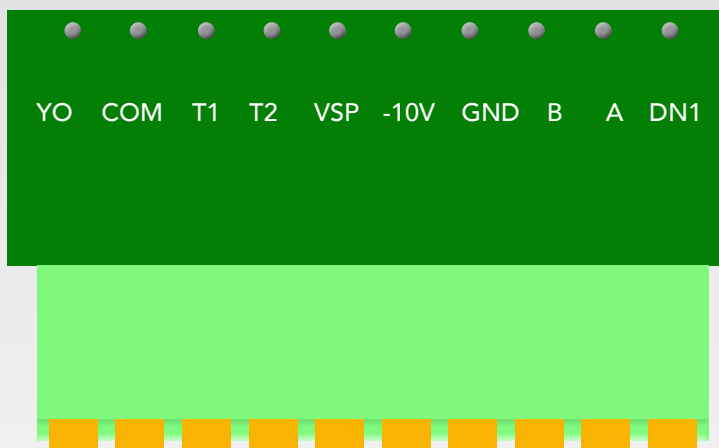

(1) Y0,COM. The internal circuit is shown below. Provide relay on/off signal. Default meter detects device failure (you can control whether this function is disabled or not by bit5 of device_config). Under normal conditions, the relay is closed. In case of fault, the relay is open.

Note: External power supply is required. It is recommended to use under 60Vdc, and the continuous operating current is less than 100mA.

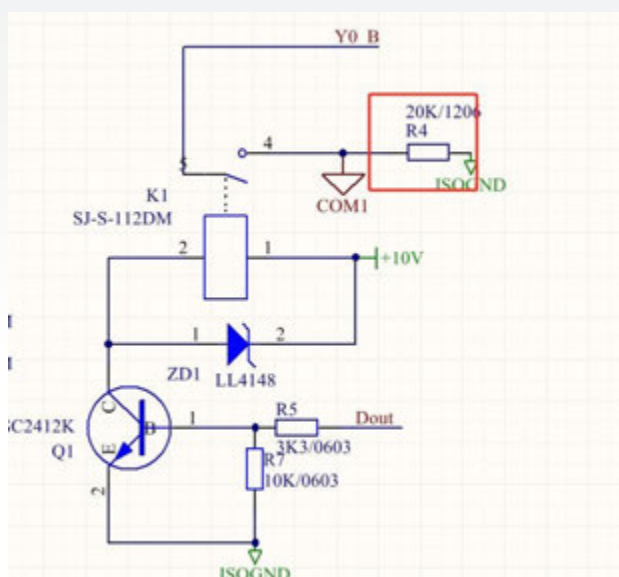

(2) T1,T2 are temperature sensor interfaces and require the use of temperature sensors capable of actively supplying 4-20mA. The following are T1 internal circuit (4~20mA_T1 is external interface, T1 is internal ADC interface).

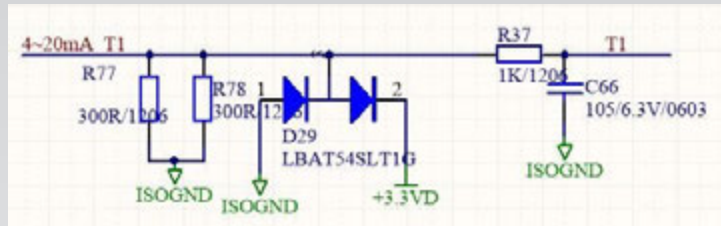

(3) The VSP can receive external PWM signals or analogue signals from 0 to 10V. It is mainly used for pressure sensors with external 0-10V output

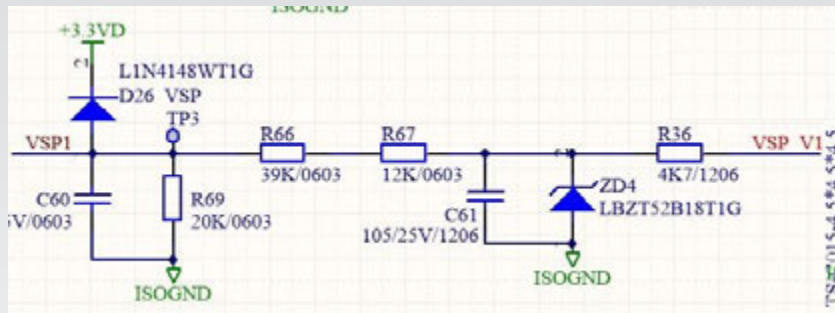

(4) The 10V interface can supply 10V externally with an output carry current of no more than 50mA.

(5) GND is the external reference ground. (Reference ground when using 10V, or RS485.)

(6) B:Negative terminal of RS485.

(7) A:Positive end of RS485.

(8) DIN1. internal circuit diagram. Pull-up resistor 470k. external control device start/stop function can be turned on by setting bit4 of device_config to 1 (not turned on by default). The internal pull-up will work when the external device is not connected, so by default, the pump will be in the working state after the external IO control function is turned on, and it needs to stop working after pulling DIN1 to GND.

Note: Can be externally controlled with an on/off signal referenced to ISOGND. It is also possible to use the 10v supplied by the port, or an external 24v power supply referenced to ISOGND.

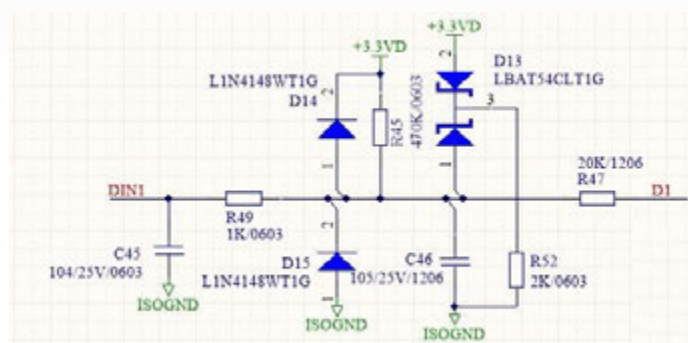



Dudullu Organize Sanayi Bölgesi 2. Cad. No: 14
34775 Ümraniye - İstanbul / Türkiye
Tel : +90 216 561 47 74 (Pbx) • Fax : +90 216 561 47 50
www.etna.com.tr • info@etna.com.tr



ETNA®

0850 455 38 62
— customer service —