

Sewage & Drainage Pumps



EFP T Series

- Suitable for residential applications such as detached houses and apartments and designed for use discharging polluted water containing solid particles up to 30 mm.
- Can be installed in sewage tanks, wastewater collection tanks, and similar fixed wastewater collection reservoirs and automatically discharges wastewater when the water collection reservoirs start to fill.
- The product is lightweight and portable and ideal for quickly discharging water when places below the elevation level become flooded.

Pump Specifications

Pump Casing	: Polypropylene
Impeller	: Polypropylene
Pump Shaft	: AISI 304 Stainless Steel
Mechanical Seal	: Carbon/Ceramic

Technical Specifications

Maximum Flow Rate	: 12 m ³ /h
Maximum Pressure	: 8.5 mwc
Maximum Solid Particle Permeability	: 10 mm
Pump Discharge Diameter	: 1"
Fluid Temperature	: 0 - 40 °C
Maximum Immersion Depth	: 5 m
Speed	: 2900 rpm
Power Supply	: 1 ~ 220 V - 50 Hz
Motor Power	: 0.4 - 0.75 kW
Protection Class	: IP68
Insulation Class	: F

- Thermal protection for the motor against overloading.
- Float switch for automatic operation.
- 10 m H07 RN-F type power cable included.

MODEL	VOLTAGE V	POWER Hp	DISCHARGE DIAMETER	L/min	0	33	67	100	133	167	200
				m ³ /h	0	2	4	6	8	10	12
EFP-040T	220	0.55	1"	Hm (mwc)	7.5	6.5	5	3.6			-
EFP-075T	220	1	1"		8.5	8.1	7.4	6.3	5	2.5	1.6



EFP K Series

- Suitable for residential applications such as detached houses and apartments and designed for use discharging clean and lightly polluted water containing solid particles up to 25 mm.
- Can be installed in water tanks, cisterns, garage drains, and similar fixed water collection reservoirs and automatically discharges water when the water collection reservoirs start to fill.
- The product is lightweight and portable and ideal for quickly discharging water when places below the elevation level become flooded.

Pump Specifications

Pump Casing	: Polypropylene
Impeller	: Polypropylene
Pump Shaft	: AISI 304 Stainless Steel
Shredder Blade	: Carbon/Ceramic
Mechanical Seal	: Carbon/Ceramic

Technical Specifications

Maximum Flow Rate	: 12 m ³ /h
Maximum Pressure	: 8 mwc
Maximum Solid Particle Permeability	: 25 mm
Pump Outlet Diameter	: 1"
Fluid Temperature	: 0 - 40 °C
Maximum Immersion Depth	: 5 m
Speed	: 2900 rpm
Power Supply	: 1 ~ 220 V - 50 Hz
Motor Power	: 0.75 kW
Protection Class	: IP68
Insulation Class	: F

- Thermal protection for the motor against overloading.
- Float switch for automatic operation.
- 10 m H07 RN-F type power cable included.

MODEL	VOLTAGE V	POWER Hp	DISCHARGE DIAMETER	L/min	0	8	17	25	33	42	50
				m ³ /h	0	0.5	1	1.5	2	2.5	3
EFP-075K	220	1	1"	Hm (mwc)	8.0	6.8	5.8	4.8	3.8	2.6	1.2



EFP G Series

- Suitable for residential applications such as detached houses and apartments and designed for use discharging clean and lightly polluted water containing solid particles up to 25 mm.
- Can be installed in water tanks, cisterns, garage drains, and similar fixed water collection reservoirs and automatically discharges water when the water collection reservoirs start to fill.
- The product is lightweight and portable and ideal for quickly discharging water when places below the elevation level become flooded.

Pump Specifications

Pump Casing	: Polypropylene
Impeller	: Polypropylene
Pump Shaft	: AISI 304 Stainless Steel
Shredder Blade	: Carbon/Ceramic
Mechanical Seal	: Carbon/Ceramic

Technical Specifications

Maximum Flow Rate	: 3 m ³ /h
Maximum Pressure	: 8 mwc
Maximum Solid Particle Permeability	: 25 mm
Pump Discharge Diameter	: 1"
Fluid Temperature	: 0 - 40 °C
Maximum Immersion Depth	: 5 m
Speed	: 2900 rpm
Power Supply	: 1 ~ 220 V - 50 Hz
Motor Power	: 0.75 kW
Protection Class	: IP68
Insulation Class	: F

- Thermal protection for the motor against overloading.
- Float switch for automatic operation.
- 10 m H07 RN-F type power cable included.

MODEL	VOLTAGE V	POWER Hp	DISCHARGE DIAMETER	L/min	0	8	17	25	33	42	50
				m ³ /h	0	0.5	1	1.5	2	2.5	3
ETN-075GF*	220	1	1"	Hm (mwc)	8	6.8	5.8	4.8	3.8	2.6	1.2



EFP 15D



EFP 075D



EFP 025D

EFP D Series

- Suitable for residential applications such as detached houses and apartments and designed for use discharging polluted water containing solid particles up to 30 mm.
- Can be installed in sewage tanks, wastewater collection tanks, and similar fixed wastewater collection reservoirs and automatically discharges wastewater when the water collection reservoirs start to fill.
- The product is lightweight and portable and ideal for quickly discharging water when places below the elevation level become flooded.

Pump Specifications

Pump Casing	: GG20 Cast Iron
Impeller	: AISI 304 Stainless Steel
Pump Shaft	: AISI 304 Stainless Steel
Mechanical Seal	: Double Mechanical
Seal	: Graphite - Ceramic / Ceramic - Silicon Carbide

Technical Specifications

Maximum Flow Rate	: 24 m ³ /h
Maximum Pressure	: 17.5 mwc
Maximum Solid Particle Permeability	: 10 - 25 mm
Pump Discharge Diameter	: 1 1 / 2" & 2"
Pressure Class	: PN10
Fluid Temperature	: 0 - 40 °C
Maximum Immersion Depth	: 5 m
Speed	: 2900 rpm
Mains Connection	: 1 ~ 220 V - 50 Hz
Motor Power	: 0.25 - 1.5 kW
Protection Class	: IP68
Insulation Class	: F

- Thermal protection for the motor against overloading.
- Float switch for automatic operation.
- 10 m H07 RN-F type power cable included.

MODEL	VOLTAGE V	POWER Hp	DISCHARGE DIAMETER	L/min	0	33	67	100	133	267	333	400
				m ³ /h	0	2	4	6	8	16	20	24
EFP-025D	220	0.35	1 1/4"	Hm (mwc)	8.5	8	7.3	6.2	5			
EFP-075D	220	1	2"		13.0	12.8	12.2	11.5	10.5	9.2	7.0	4.0
EFP-15D	220	2	2"		17.5	17.1	16.5	15.8	14.8	13.4	11.9	10.0

PERFORMANCE CURVE

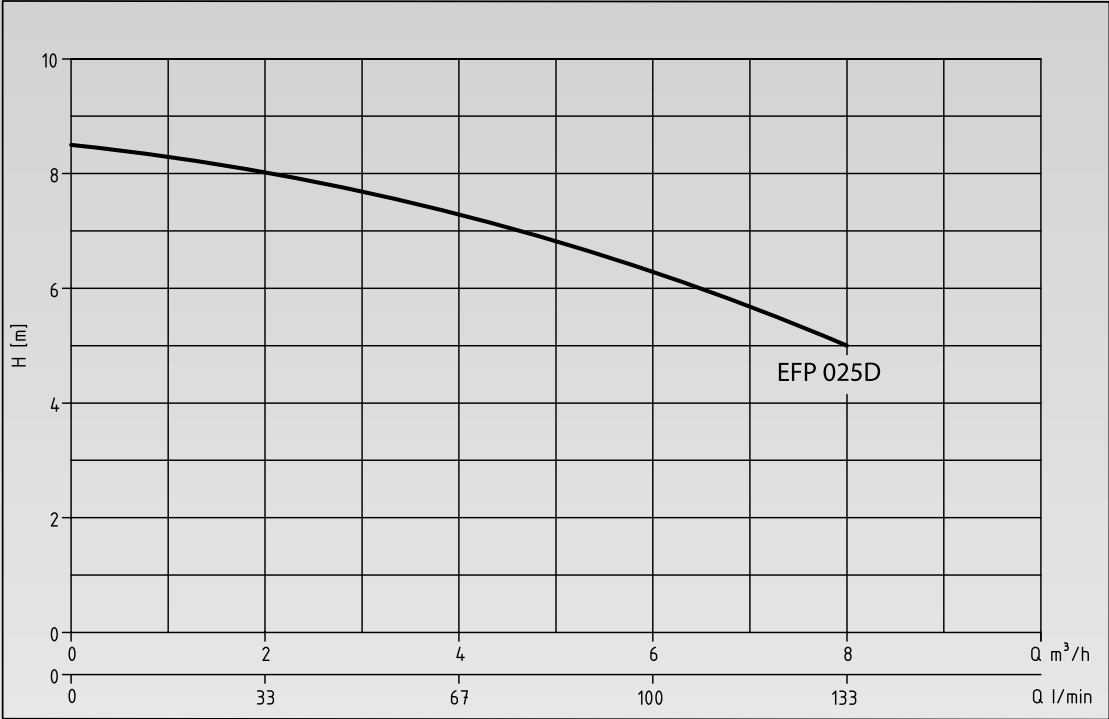

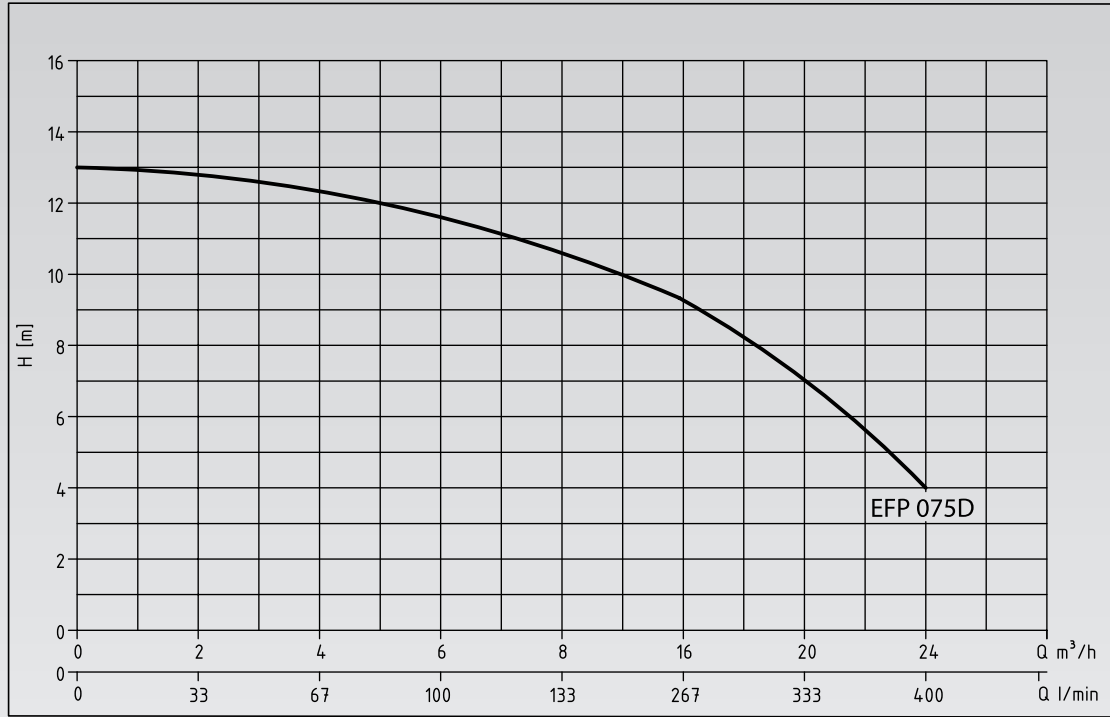

PERFORMANCE CURVE

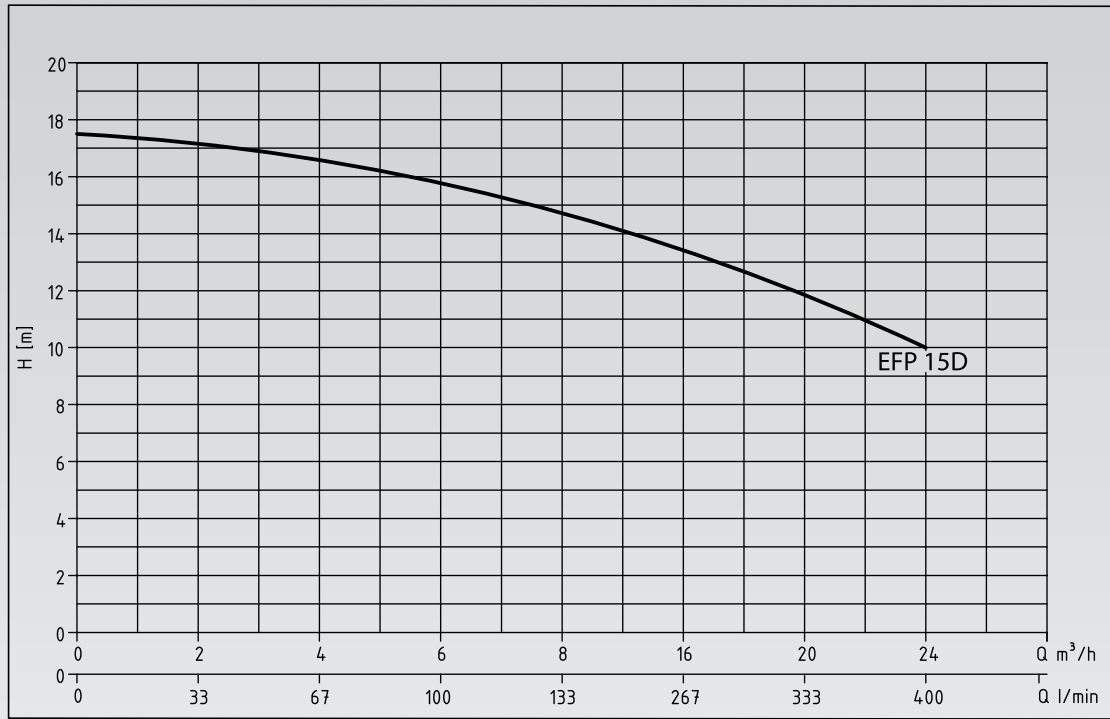



EFP-13DP



EFP-18DP



EFP 13 & 18 DP Series

- Suitable for residential and commercial applications such as apartments, schools, and hotels and designed for use discharging sewage and polluted water containing solid particles up to 50 mm (pieces of paper and textile, plastic additive waste, etc.).
- Integral blade shreds solid particles ensuring their smooth transfer.
- Can be installed in sewage tanks, wastewater collection tanks, and similar fixed wastewater collection reservoirs and automatically discharges wastewater when the water collection reservoirs start to fill.
- The product is lightweight and portable and ideal for quickly discharging water when places below the elevation level become flooded.

Pump Specifications

Pump Casing	: GG20 Cast Iron
Impeller	: GG20 Cast Iron
Pump Shaft	: AISI 304 Stainless Steel
Shredder Blade	: AISI 304 Stainless Steel
Seal	: Graphite - Ceramic / Ceramic - Silicon Carbide

Technical Specifications

Maximum Flow Rate	: 25 m ³ / h
Maximum Pressure	: 24 mwc
Maximum Solid Particle Permeability	: 50 mm
Pump Discharge Diameter	: 2"
Pressure Class	: PN10
Fluid Temperature	: 0 - 40 °C
Maximum Immersion Depth	: 10 m
Speed	: 2900 rpm
Mains Connection	: 1 ~ 220 V - 50 Hz
Motor Power	: 1.3 - 1.8 kW
Protection Class	: IP68
Insulation Class	: F

- Thermal protection for the motor against overloading.
- Float switch for automatic operation.
- 10 m H07 RN-F type power cable included.

TECHNICAL SPECIFICATIONS

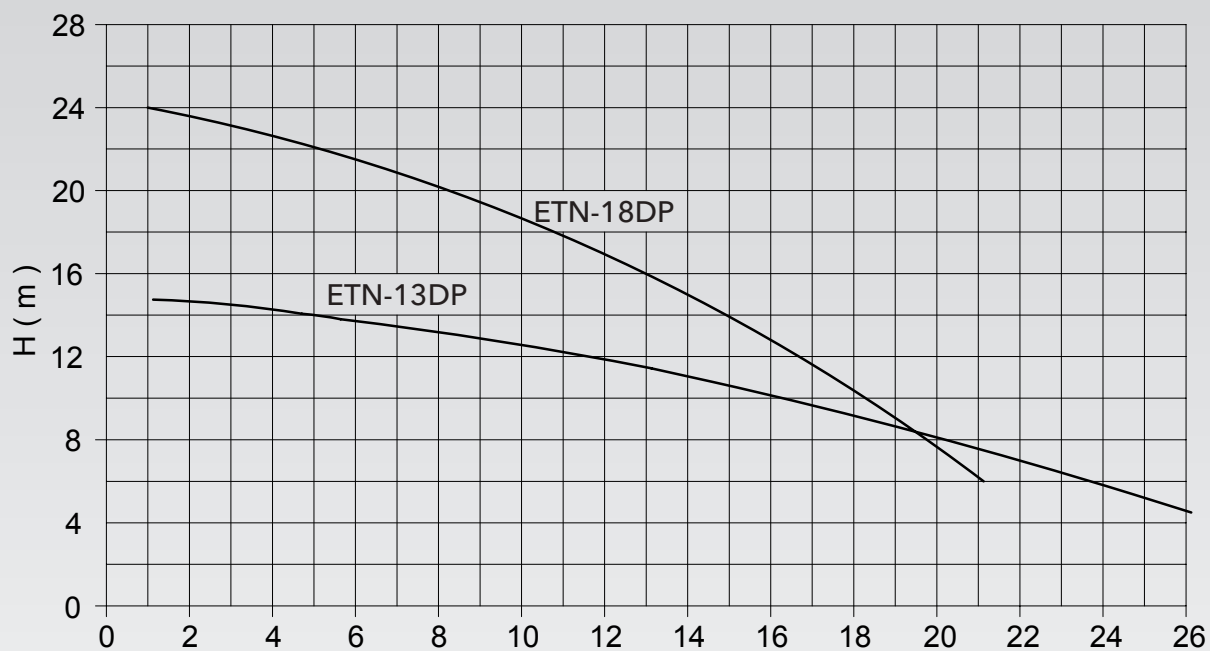

MODEL	VOLTAGE V	POWER Hp	DISCHARGE DIAMETER	L/min	0	67	133	200	267	333	417
				m ³ /h	0	4	8	12	16	20	25
EFP-13DP	220	1.8	2"	Hm	15.0	14	13.0	11.5	9.8	7.8	4.5
EFP-18DP	220	2.4	2"	(mwc)	24.0	22.0	19.0	16	11.7	6.0	

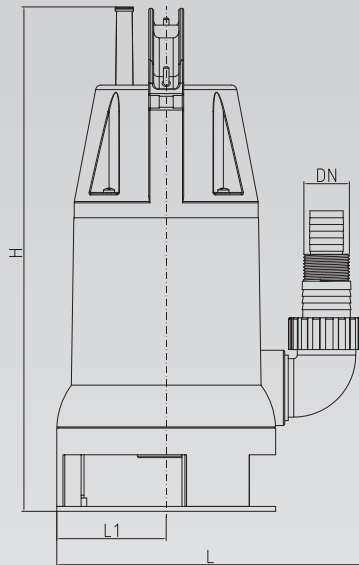

MODEL	DIMENSIONS (mm)						
	DNM	B	B	L	N	H1	H2
EFP 040T	1"	220	130	160	110	250	310
EFP 075T	1"	230	130	160	115	280	330
EFP 075K	1"	220	190	160	140	310	370

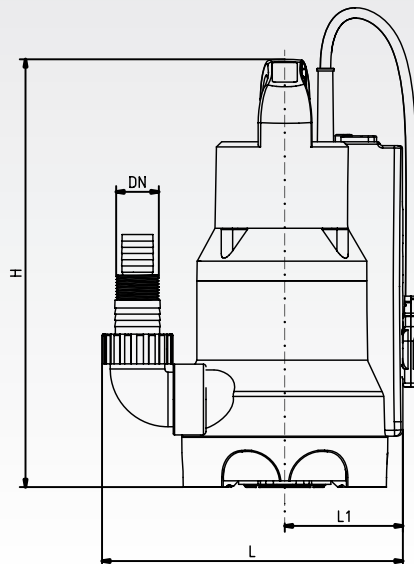

MODEL	DIMENSIONS (mm)				
	DNM	B	B	L	N
ETN-075GF	1"	330	230	90	110

DIMENSIONS

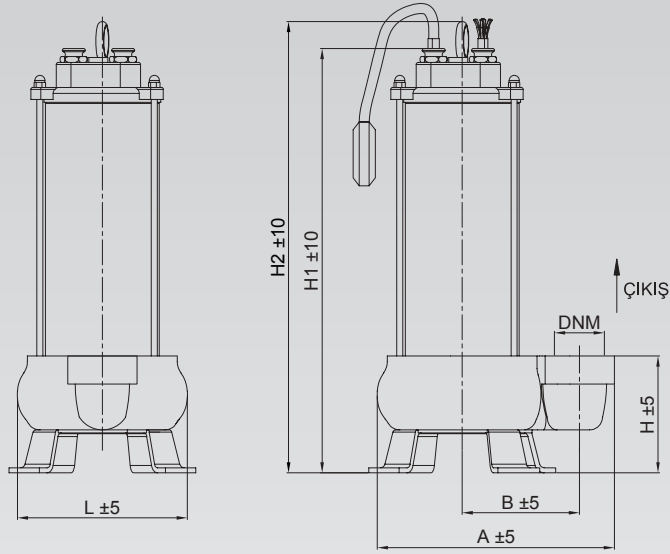

MODEL	DIMENSIONS (mm)						
	DNM	B	B	L	N	H1	H2
EFP 025D	1 1/4"	170	90	130	90	350	400
EFP 075D	2"	230	200	170	120	380	430
EFP 15D	2"	260	230	180	120	470	520
EFP 13DP	2"	330	220	190	140	430	490
EFP 18DP	2"	430	350	200	190	500	600

EFP 11 D / DP / DV Series



EFP 11 DP



EFP 11 D



EFP 11 DV

- **EFP 11 DP:** Pumps designed for transferring waste and sewage water containing solid particles (pieces of paper and textile, plastic additive waste, etc.) and discharging solid particles smoothly by shredding them with its integral blade.
- **EFP 11 D:** Pumps with an open impeller and stainless steel filter, ideal for discharging slightly polluted water containing particles up to 6 mm.
- **EFP 11 DV:** Pumps with vortex impellers, designed for intense use and ideal for discharging polluted water containing particles up to 35 mm.

Pump Specifications

Pump Casing	: GG25 Cast Iron
Impeller	: GG25 Cast Iron
Pump Shaft	: AISI 420 Stainless Steel
Shredder Blade	: AISI 420 Stainless Steel
Mechanical Seal	: Carbon/Ceramic/EPDM

Technical Specifications

Maximum Flow Rate	: 18 m ³ /h
Maximum Pressure	: 20.4 mwc
Maximum Solid Particle Permeability	: 6 - 35 mm
Connection Diameter	: 1 1/2" & 2"
Pressure Class	: PN10
Fluid Temperature	: 0 - 40 °C
Immersion Depth	: 5 - 10 m
Speed	: 2900 rpm
Mains Connection	: 1 ~ 220 V - 50 Hz
Motor Power	: 1.1 kW
Protection Class	: IP68
Insulation Class	: F

- Should be used with an appropriate protection control panel and a compatible check valve.
- Thermal protection for the motor against overloading.
- Float switch for automatic operation.
- 10 m H07 RN-F type power cable included.

Note: In order for the product to be covered by the warranty, it must be used with the Hydropan pump controller and the first operation must be performed by our authorized services.

TECHNICAL SPECIFICATIONS

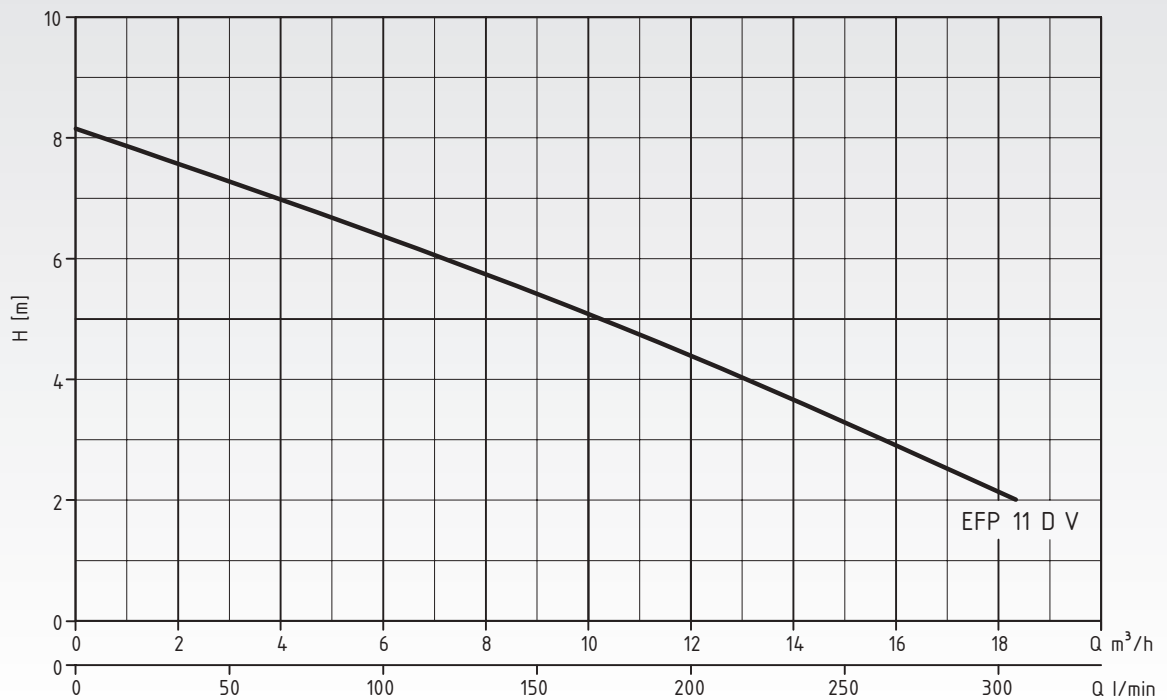
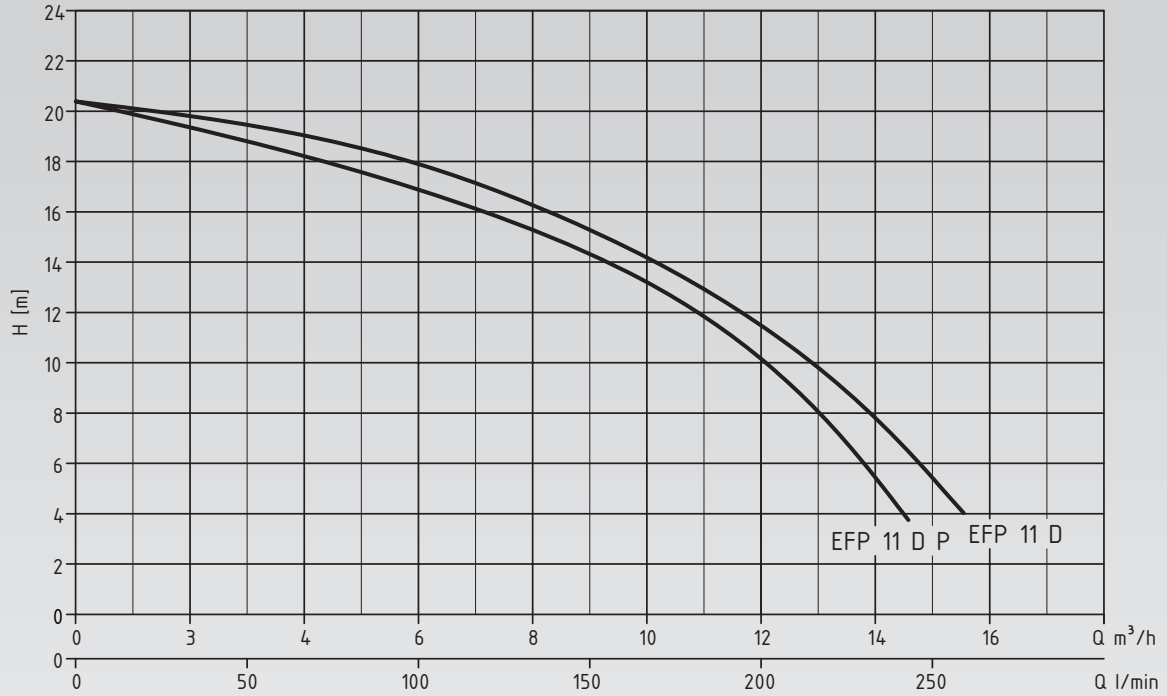

MODEL	VOLTAGE V	POWER Hp	DISCHARGE DIAMETER	L/min	0	50	100	150	200	250	300
				m³/h	0	3	6	9	12	15	18
EFP 11 DP	220	1.1	1 1/2" G	Hm (mwc)	20.4	18.3	16.3	14.3	10.2	2	
EFP 11 D	220	1.1	1 1/2" G		20.4	19.3	17.8	15	11.3	5.1	
EFP 11 DV	220	1.1	2" G		8.2	7.3	6.3	5.3	4.2	3.1	2

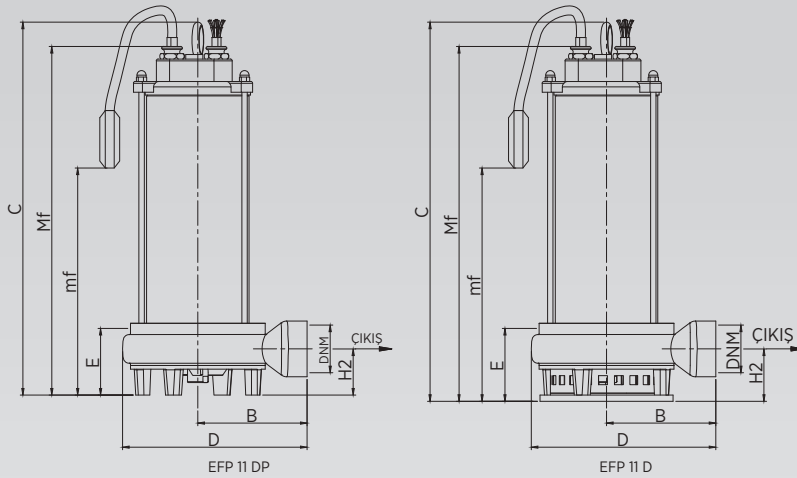

EFP 11 DP

EFP 11 D

Packaging Dimensions

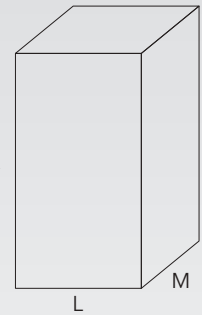

W: Maximum discharge level

Mf: The lowest level for continuous operation

MODEL	DIMENSIONS (mm)											
	B	C	Mf	D	Y	H2	mf	DNM	K	L	M	Kg
EFP 11 DP	122	420	395	205	80	58	300	1 1/2"G	460	300	300	19.5
EFP 11 D	122	425	400	205	85	63	300	1 1/2"G	460	300	300	19

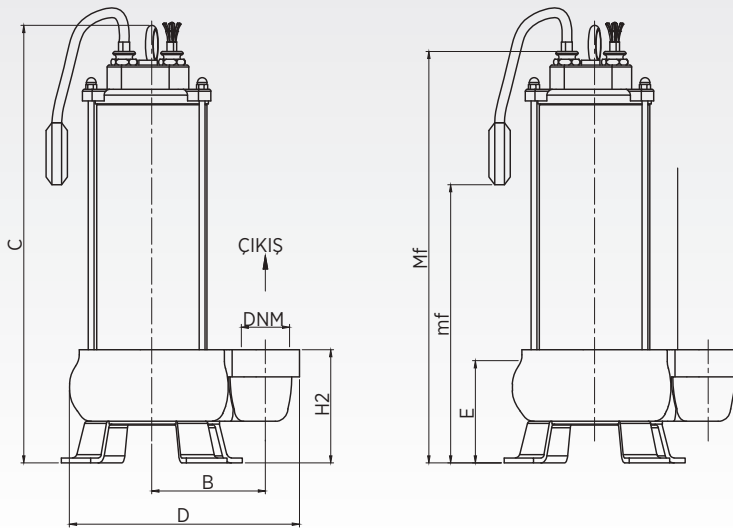

EFP 11 DV

Packaging Dimensions

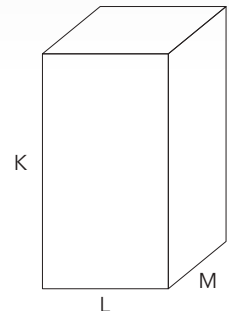

W: Maximum discharge level

Mf: The lowest level for continuous operation

MODEL	DIMENSIONS (mm)											
	B	C	Mf	D	Y	H2	mf	DNM	K	L	M	Kg
EFP 11 DV	109	425	452	240	100	117	300	2"G	460	300	300	19



EFP 26 DT



EFP 22 DP



EFP 22-26 D / DP / DT / DV Series

- **EFP 22 DP:** Pumps designed for transferring waste and sewage water containing solid particles (pieces of paper and textile, plastic additive waste, etc.) and discharging solid particles smoothly by shredding them.
- **EFP 22 D:** Pumps with an open impeller and stainless steel filter, ideal for discharging slightly polluted water containing particles up to 6 mm.
- **EFP 26 DV:** Pumps with vortex impellers, designed for intense use and ideal for discharging contaminated water containing particles up to 40 mm.
- **EFP 26 DT:** Pumps with single impellers, designed for intense use and ideal for discharging polluted water containing particles up to 50 mm.

Pump Specifications

Pump Casing	: GG25 Cast Iron
Impeller	: GG25 Cast Iron
Pump Shaft	: AISI 420 Stainless Steel
Shredder Blade	: AISI 420 Stainless Steel
Mechanical Seal	: Carbon/Ceramic/EPDM

Technical Specifications

Maximum Flow Rate	: 42 m ³ /h
Maximum Pressure	: 24.5 mwc
Maximum Solid Particle Permeability	: 6 - 50 mm
Connection Diameter	: 2" & DN65
Pressure Class	: PN10
Fluid Temperature	: 0 - 40 °C
Immersion Depth	: 10 m
Speed	: 2900 rpm
Mains Connection	: 3 ~ 380 V - 50 Hz
Motor Power	: 2,4 kW (D/DP) & 2,6 kW (DT/DV)
Protection Class	: IP68
Insulation Class	: F

- Should be used with an appropriate protection control panel and a compatible check valve.
- Thermal protection for the motor against overloading.
- Float switch for automatic operation.
- 10 m H07 RN-F type power cable included.

Note: Original ETNA protection - pump controller panels should be used with drainage pumps with three-phase (380V-50Hz) electric supply. Damage that may occur when original three-phase ETNA protection - pump controller panels are not used is not covered by warranty.

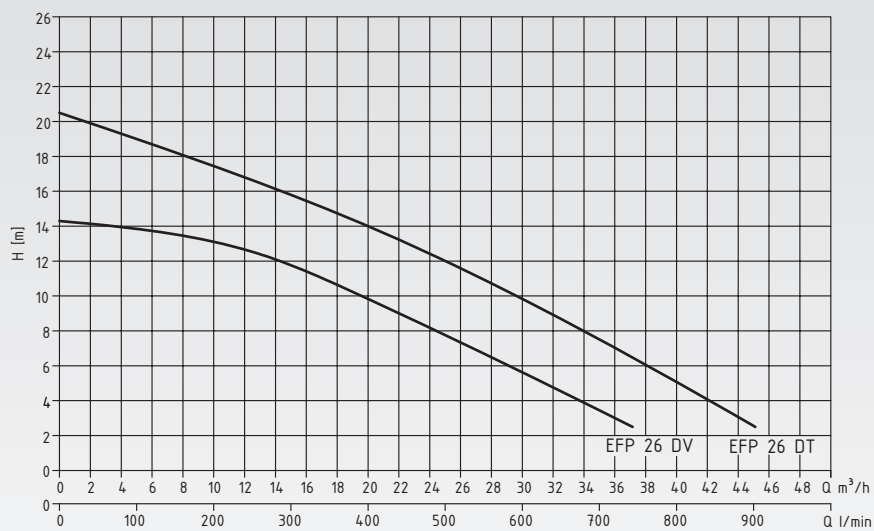
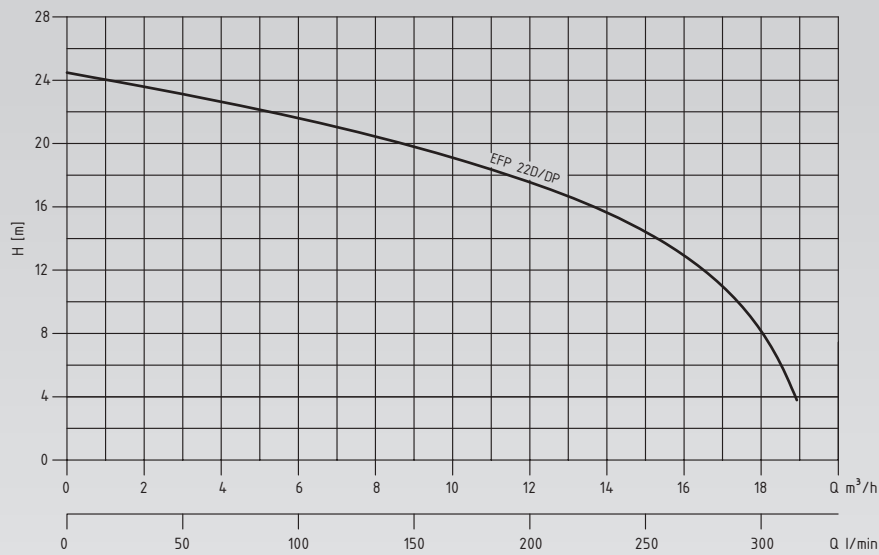

MODEL	VOLTAGE V	POWER kW	DISCHARGE DIAMETER	lt/min	0	50	100	150	200	250	300
				m³/h	0	3	6	9	12	15	18
EFP 22 DP	380	2,2	2"	Hm	24,5	23	21,6	19,8	17,5	14,4	8
EFP 22 D	380	2,2	2"	(mSS)	24,5	23	21,6	19,8	17,5	14,4	8

MODEL	VOLTAGE V	POWER kW	DISCHARGE DIAMETER	lt/min	0	100	200	300	400	500	600	700
				m³/h	0	6	12	18	24	30	36	42
EFP 26 DV	380	2,6	DN 65	Hm	14,5	14	12,6	10,5	8	5,9	3	
EFP 26 DT	380	2,6	DN 65	(mSS)	20,5	18,5	16,5	14,5	12,5	10	7	4

DIMENSIONS

The lifting rail is a fitting that provides ease of installation and maintenance in cases where the pump is required to run on a fixed point. With its lifting rail system, the pump is easily suspended into a well using a chain through its stainless steel guide pipes, and when it is directly across from the flange located at the bottom of the lifting rail, it sits onto the discharge flange and is ready for operation.

Eliminates the need to drain the chamber where the pump is located for servicing and maintenance.

When the pump requires servicing and maintenance, it can be removed easily by pulling it up with the chain then spraying it with clean water before servicing. The pump is lowered back into the well on the lifting rail after maintenance and is easily made ready for operation.

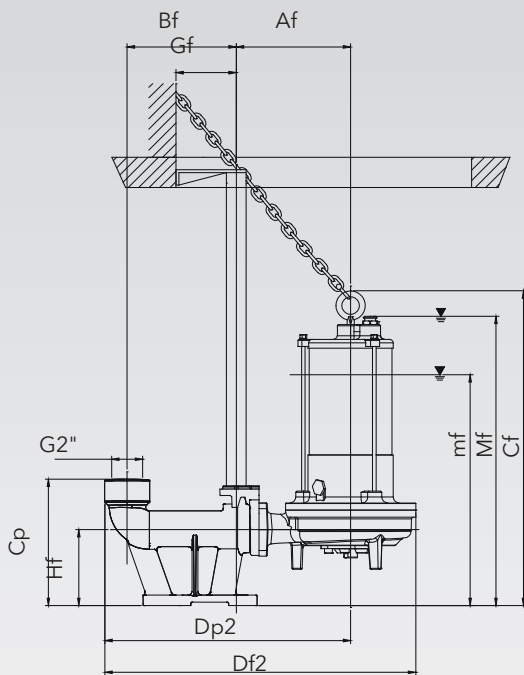

EFP 22DP

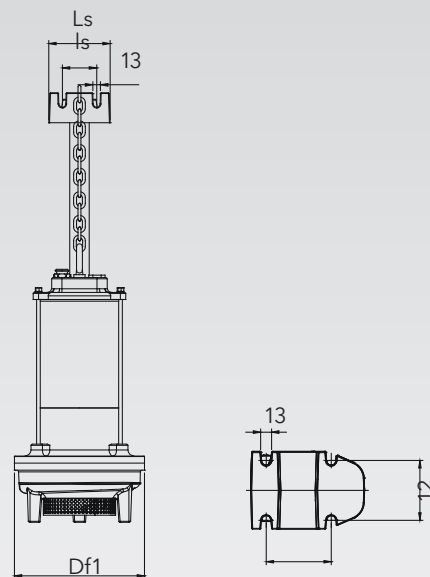

EFP 22 D

W: Maximum discharge level
Mf: Minimum level for continuous operation

MODEL	DIMENSIONS (mm)																
	Af	Bf	Cf	Cp	Df1	Df2	Dp2	DNt	Gf	Hf	I1	I2	Is	Ls	mf	Mf	DNm
EFP 22 DP	195	185	462	210	220	530	410	3/4"	100	130	110	100	58	104	320	420	50
EFP 22 D	195	185	462	210	220	530	410	3/4"	100	130	110	100	58	104	320	420	50

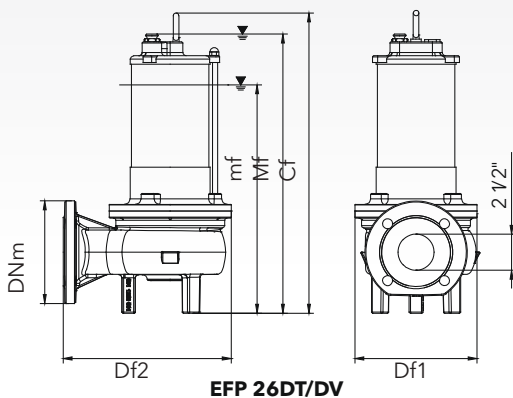

EFP 26DT/DV

MODEL	DIMENSIONS (mm)						
	Cf	Df1	Df2	Hf	mf	Mf	DNm
EFP 26DT	546	220	300	110	403	503	65
EFP26DV	546	220	300	110	403	503	65

W: Maximum discharge level

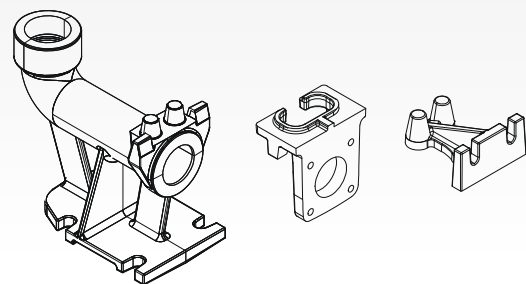

ACCESSORIES

MODEL	CONNECTION DIAMETER	SUITABLE PUMP MODELS
Slide system mounting kit	G2"	EFP 22 DP - EFP 22 D

SEWAGE PUMP INSTALLATION AND WELL DETAILS



Applicable models: EFP 025D-075D-15D, EFP 13DP-18DP and plastic casing sewage pump series

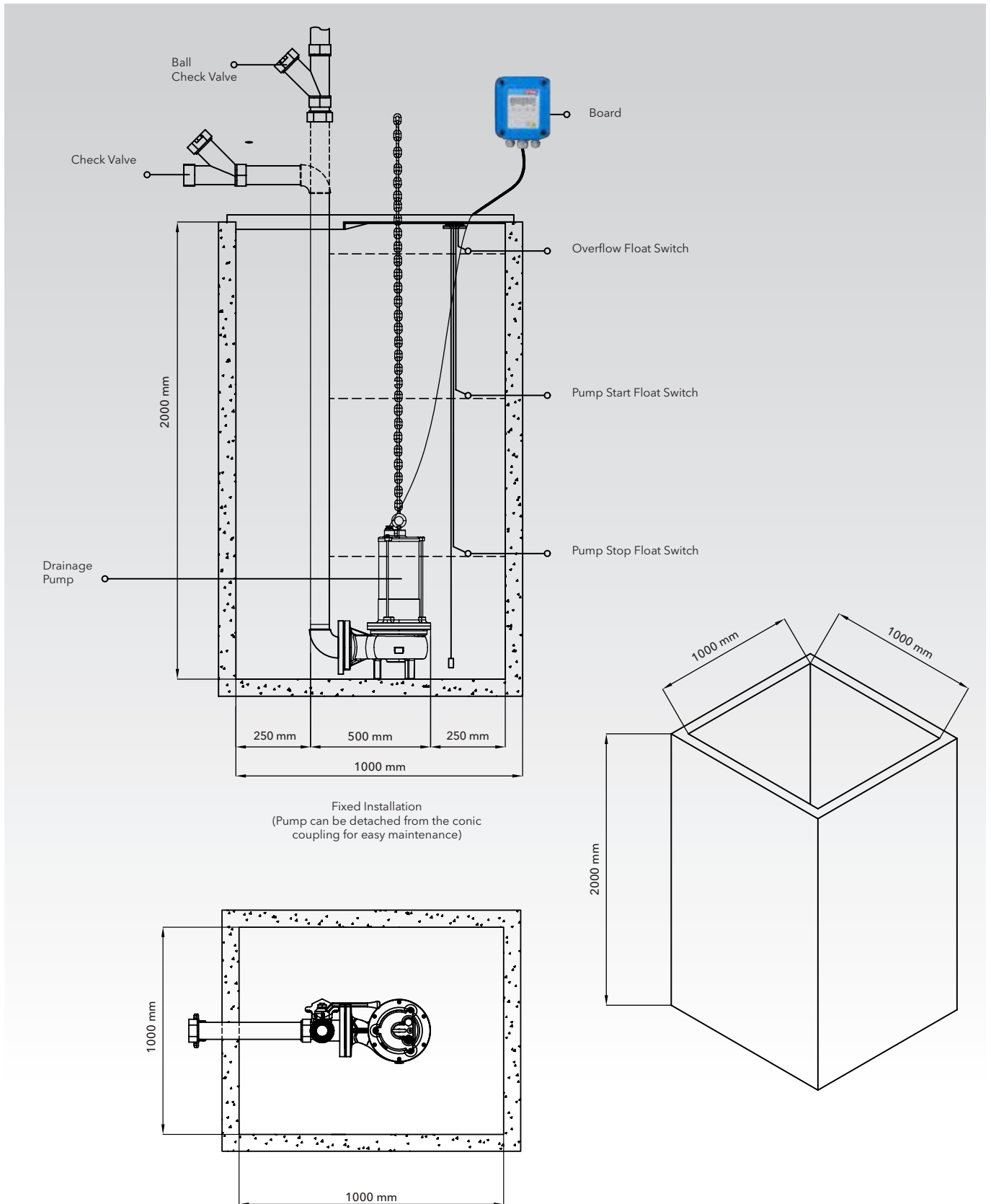

SEWAGE PUMPS WITH HIGH-FLOW GRINDER BLADE



EFP DP - 2P Series

- Designed to be used when the diameter of the suspended solid particles inside the waste water are so large for the pumps to transfer.
- Can be used for transferring domestic wastes such as paper towels and tissues, animal wastes in slaughter houses and industrial and textile wastes containing fibers by shredding them into smaller pieces.

Pump Specifications

Pump Casing	: GG20 Cast Iron
Impeller	: GG20 Cast Iron
Pump Shaft	: AISI 304 Stainless Steel
Shredder Blade	: AISI 420 Stainless Steel
Mechanical Seal	: Carbon/Ceramic/EPDM

Technical Specifications

Maximum Flow Rate	: 180 m ³ /h
Maximum Pressure	: 37 mwc
Maximum Solid Particle Permeability	: 50 mm
Connection Diameter	: DN65 - DN150
Pressure Class	: PN10
Fluid Temperature	: 0 - 40 °C
Immersion Depth	: 20 m
Speed	: 2900 rpm
Mains Connection	: 3 ~ 380 V - 50 Hz
Motor Power	: 3 - 15 kW
Protection Class	: IP68
Insulation Class	: F



- Should be used with an appropriate protection control panel and a compatible ball-type check valve.
- Thermal protection for the motor against overloading.
- 10 m H07 RN-F type power cable included.

Note: Original ETNA protection - pump controller panels should be used with drainage pumps with three-phase (380V-50Hz) electric supply. Damage that may occur when original three-phase ETNA protection - pump controller panels are not used is not covered by warranty.

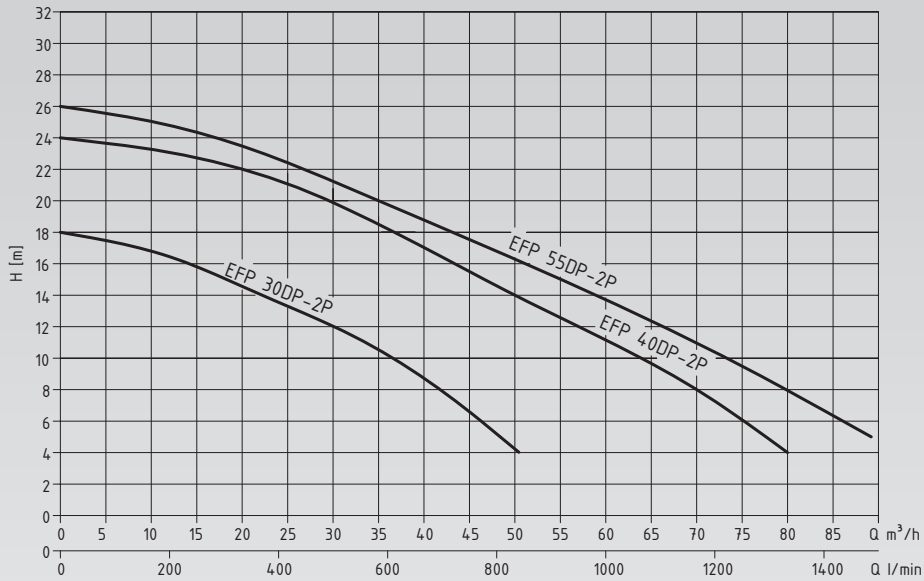

MODEL	L/min	0	167	333	500	667	833	1000	1167	1333
	m³/h	0	10	20	30	40	50	60	70	80
EFP 30DP-2P	Hm (mwc)	18	17	14.5	12	8.5	4	-	-	-
EFP 40DP-2P		24	23	22	20	17	14	11	8	4
EFP 55DP-2P		26	25	23.5	21	19	16	14	11	8

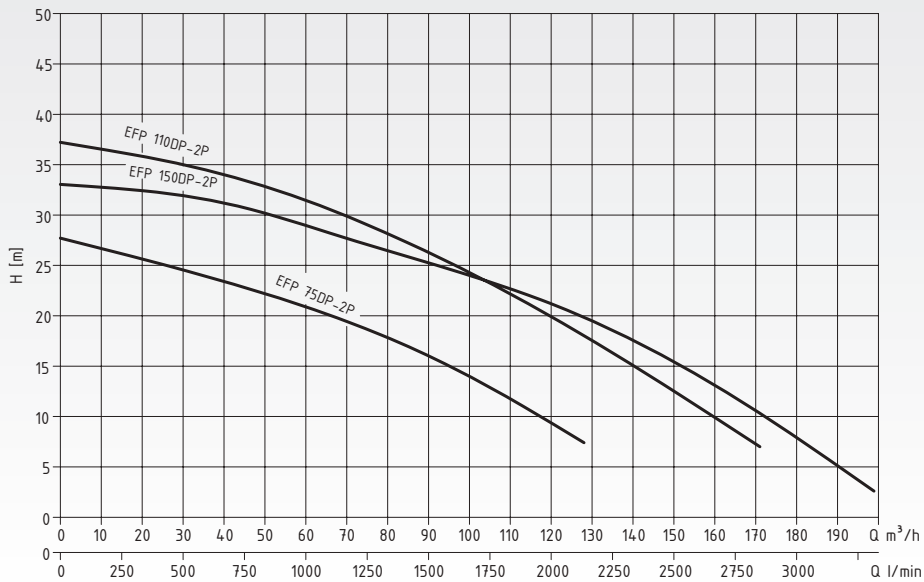

MODEL	L/min	0	333	667	1000	1333	1667	2000	2333	2667	3000
	m³/h	0	20	40	60	80	100	120	140	160	180
EFP 75DP-2P	Hm (mwc)	27.5	25.5	23	21	17.5	14	9	-	-	-
EFP 110DP-2P		37	36	34	32	28	24	20	15	10	-
EFP 150DP-2P		33.5	33	31	29	26	24	21	17.5	13	8



EFP D - 2P Series

- Designed with high solid particle permeability for discharging drainage water requiring high flow/pressure in residential and commercial buildings (hotels, hospitals, dorms etc.) and industrial facilities.

Pump Specifications

Pump Casing	: GG20 Cast Iron
Impeller	: GG20 Cast Iron
Pump Shaft	: AISI 304 Stainless Steel
Mechanical Seal	: Carbon/Ceramic/EPDM

Technical Specifications

Maximum Flow Rate	: 160 m ³ /h
Maximum Pressure	: 47.5 mwc
Maximum Solid Particle Permeability	: 20 - 35 mm
Connection Diameter	: DN80 - DN100
Pressure Class	: PN10
Fluid Temperature	: 0 - 40 °C
Immersion Depth	: 20 m
Speed	: 2900 rpm
Mains Connection	: 3 ~ 380 V - 50 Hz
Motor Power	: 3 - 18.5 kW
Protection Class	: IP68
Insulation Class	: F

- Should be used with an appropriate protection control panel and a compatible ball-type check valve.
- Thermal protection for the motor against overloading.
- 10 m H07 RN-F type power cable included.

Note: Original ETNA protection - pump controller panels should be used with drainage pumps with three-phase (380V-50Hz) electric supply. Damage that may occur when original three-phase ETNA protection - pump controller panels are not used is not covered by warranty.

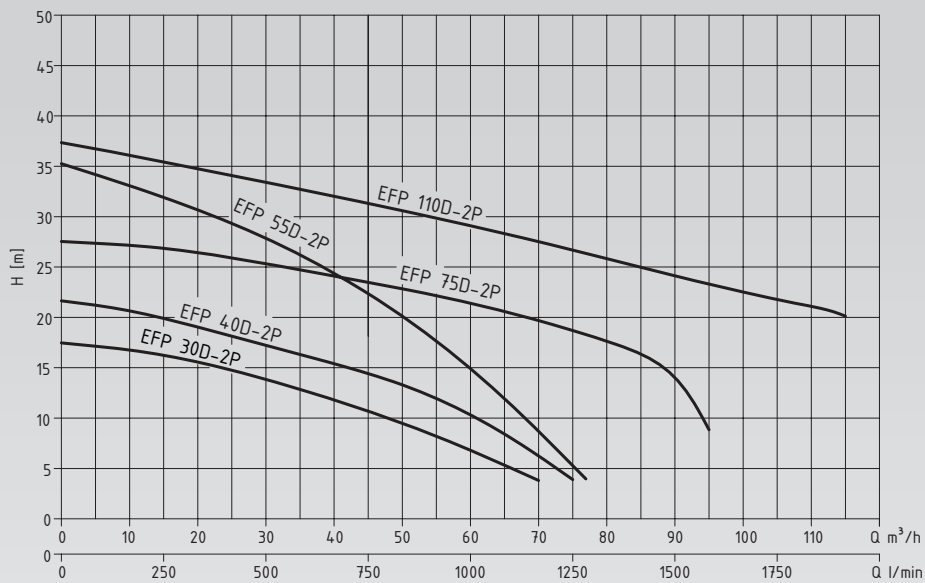

MODEL	L/min	0	167	333	500	667	833	1000	1167	1333	1500	1667	1833
	m ³ /h	0	10	20	30	40	50	60	70	80	90	100	110
EFP 30D-2P	Hm (mwc)	17	16	15.5	14	12	10	7	4	-	-	-	-
EFP 40D-2P		22	20.5	19	17.5	15	13	10	6	4	-	-	-
EFP 55D-2P		35	33	30	28	25	20	15	8	-	-	-	-
EFP 75D-2P		27.5	27	26	25	24	23	22	20	18	14	-	-
EFP 110D-2P		37	36	35	33	32	30.5	29	27.5	26	24	22.5	21

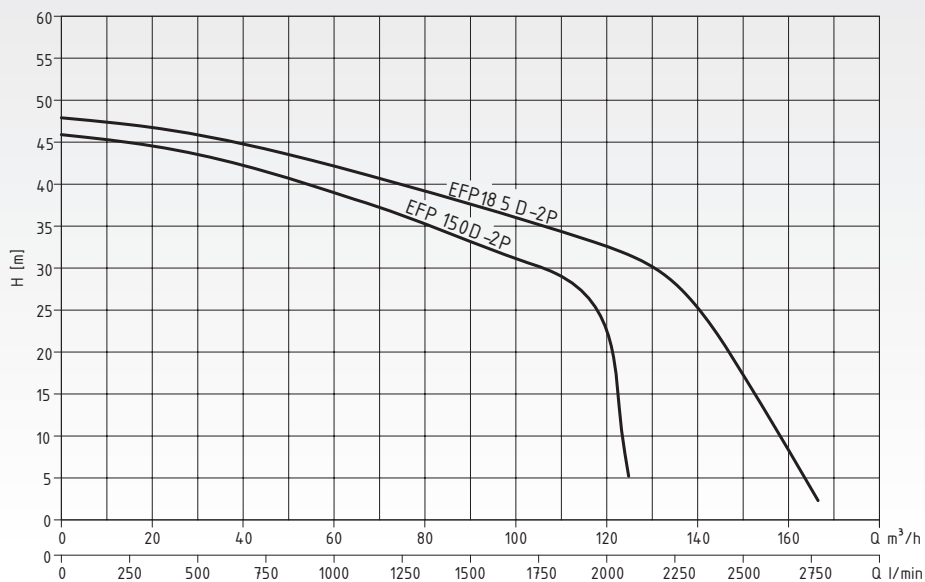

MODEL	L/min	0	333	667	1000	1333	1667	2000	2333	2667
	m ³ /h	0	20	40	60	80	100	120	140	160
EFP 150D-2P	Hm (mwc)	45.5	45	42	39	35	31	22.5	-	-
EFP 185D-2P		47.5	46.5	45	42.5	39	36	32.5	25	7



EFP D - 4P Series

- Designed with high solid particle permeability for discharging drainage water requiring high flow/pressure in residential and commercial buildings (hotels, hospitals, dorms etc.) and industrial facilities.

Pump Specifications

Pump Casing	: GG20 Cast Iron
Impeller	: GG20 Cast Iron
Pump Shaft	: AISI 304 Stainless Steel
Mechanical Seal	: Carbon/Ceramic/EPDM

Technical Specifications

Maximum Flow Rate	: 360 m ³ /h
Maximum Pressure	: 29 mwc
Maximum Solid Particle Permeability	: 35 - 50 mm
Connection Diameter	: DN100 - DN400
Pressure Class	: PN10
Fluid Temperature	: 0 - 40 °C
Immersion Depth	: 20 m
Speed	: 1450 rpm
Mains Connection	: 3 ~ 380 V - 50 Hz
Motor Power	: 5.5 - 22 kW
Protection Class	: IP68
Insulation Class	: F

- Should be used with an appropriate protection control panel and a compatible ball-type check valve.
- Thermal protection for the motor against overloading.
- 10 m H07 RN-F type power cable included.

Note: Original ETNA protection - pump controller panels should be used with drainage pumps with three-phase (380V-50Hz) electric supply. Damage that may occur when original three-phase ETNA protection - pump controller panels are not used is not covered by warranty.

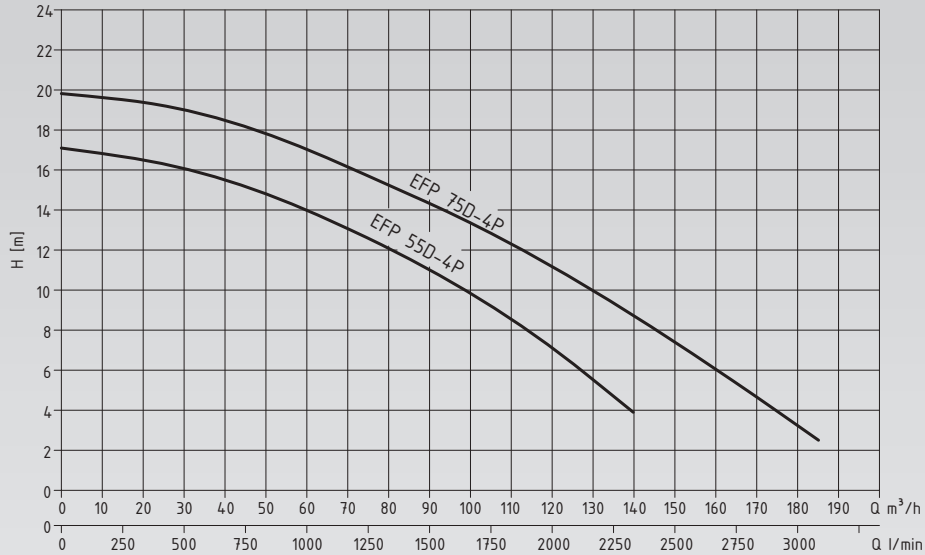

MODEL	L/min	0	333	667	1000	1333	1667	2000	2333	2667	3000
	m ³ /h	0	20	40	60	80	100	120	140	160	180
EFP 55D-4P	Hm (mwc)	17	16.5	15.5	14	12	10	7	4	-	-
EFP 75D-4P		20	19.5	18.5	17	15	13	11	8.5	6	3

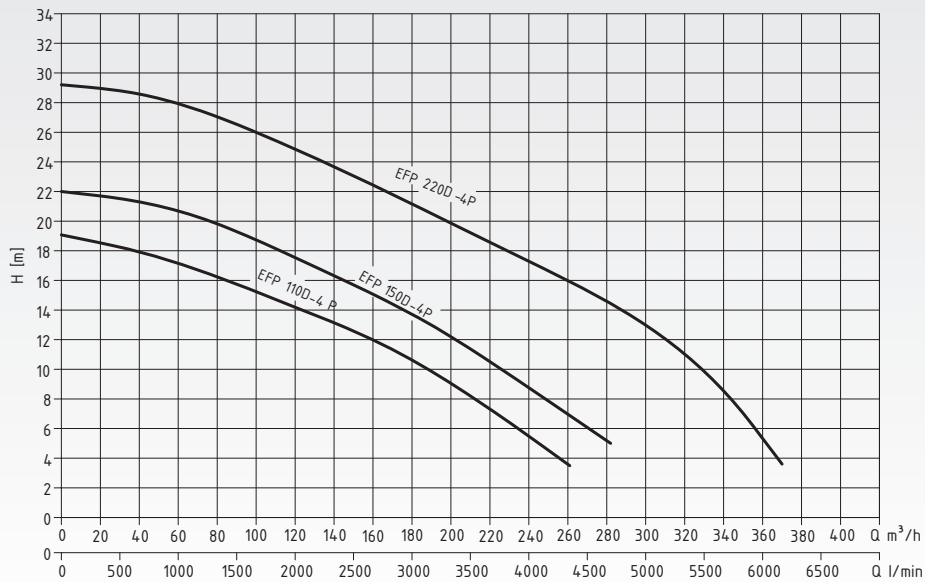

MODEL	L/min	0	667	1333	2000	2667	3333	4000	4667	5333	6000
	m ³ /h	0	40	80	120	160	200	240	280	320	360
EFP 110D-4P	Hm (mwc)	19	18	16	14	12	9	5.5	-	-	-
EFP 150D-4P		22	21.5	20	17.5	15	12	8.5	5	-	-
EFP 220D-4P		29	28.5	27	25	22	20	17	14.5	11	7

DIMENSIONS

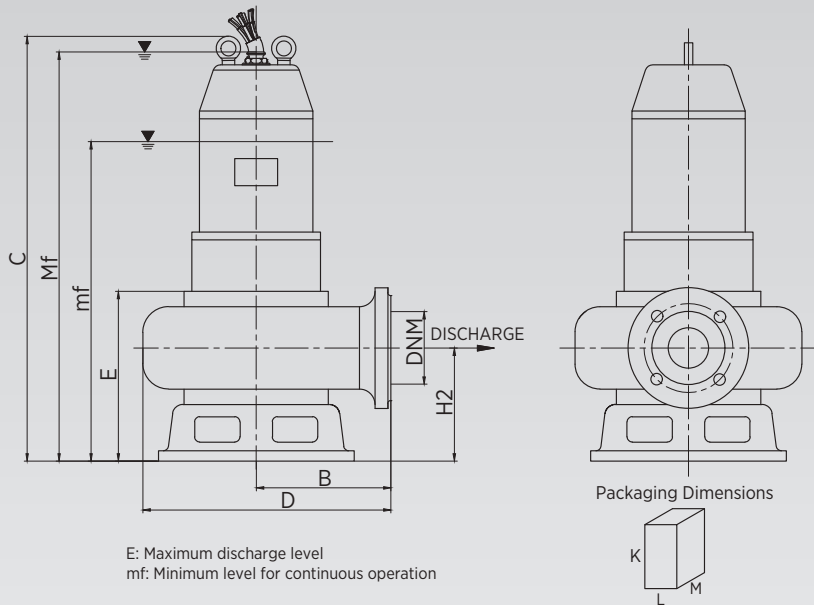

MODEL	Dimensions (mm)												Kg
	Speed	B	C	Mf	D	Y	H2	mf	DNM	K	L	M	
EFP 30DP - 2P	2900	160	575	455	280	225	123	365	65	695	340	315	35
EFP 40DP - 2P	2900	185	590	470	315	230	127	380	65	710	360	350	38
EFP 75DP - 2P	2900	195	660	540	335	240	137	450	100	780	380	370	62
EFP 110DP - 2P	2900	275	909	790	465	295	194	700	100	1030	480	500	200
EFP 150DP - 2P	2900	315	920	800	525	310	207	710	150	1040	520	560	212

MODEL	Dimensions (mm)												Kg
	Speed	B	C	Mf	D	Y	H2	mf	DNM	K	L	M	
EFP 30D - 2P	2900	170	660	540	290	250	150	450	80	780	340	325	46
EFP 40D - 2P	2900	210	690	570	340	250	150	480	80	810	360	375	57
EFP 55D - 2P	2900	200	780	660	350	275	175	570	80	900	400	385	72
EFP 75D - 2P	2900	200	810	690	350	275	175	600	100	930	400	385	98
EFP 110D - 2P	2900	255	850	730	375	260	160	640	100	970	340	410	125
EFP 150D - 2P	2900	255	887	770	375	260	160	680	100	1010	340	410	136
EFP 185D - 2P	2900	335	1238	1120	567	325	223	1030	150	1060	565	705	250

MODEL	Dimensions (mm)												Kg
	Speed	B	C	Mf	D	Y	H2	mf	DNM	K	L	M	
EFP 55D - 4P	1450	227	800	680	407	280	180	590	100	920	460	445	109
EFP 75D - 4P	1450	220	860	740	400	280	180	650	100	980	460	435	114
EFP 110D - 4P	1450	525	939	820	525	305	206	730	150	1060	520	560	206
EFP 150D - 4P	1450	309	979	860	525	305	206	770	150	1100	535	560	229
EFP 220D - 4P	1450	347	1264	1145	567	335	233	1055	200	1385	540	605	325

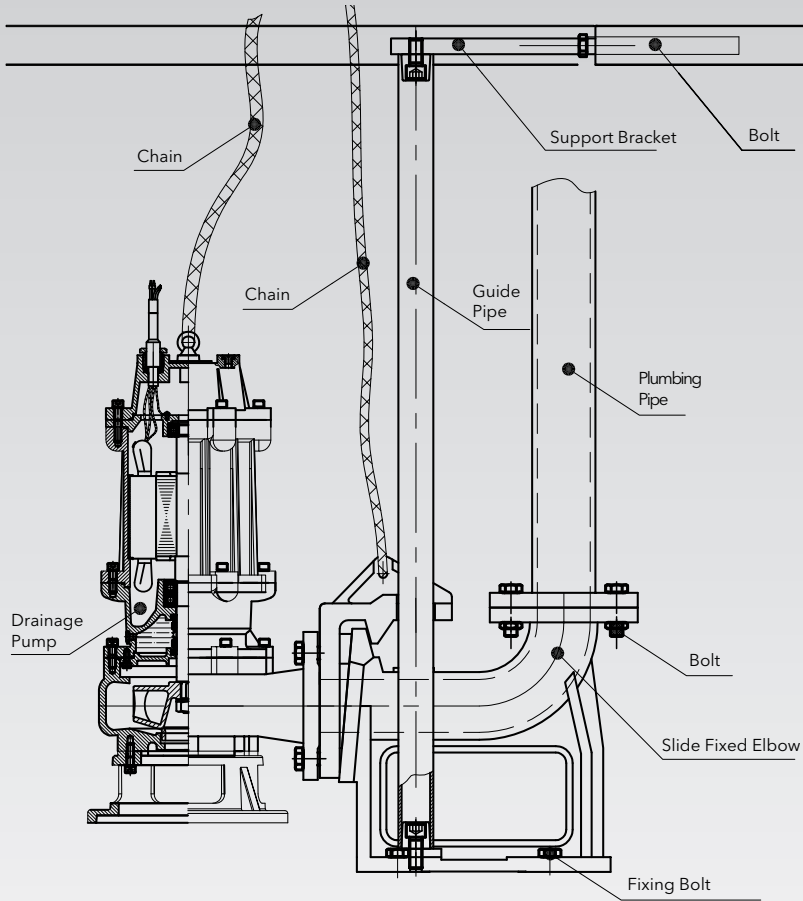

Guide Pipe Fixing Part

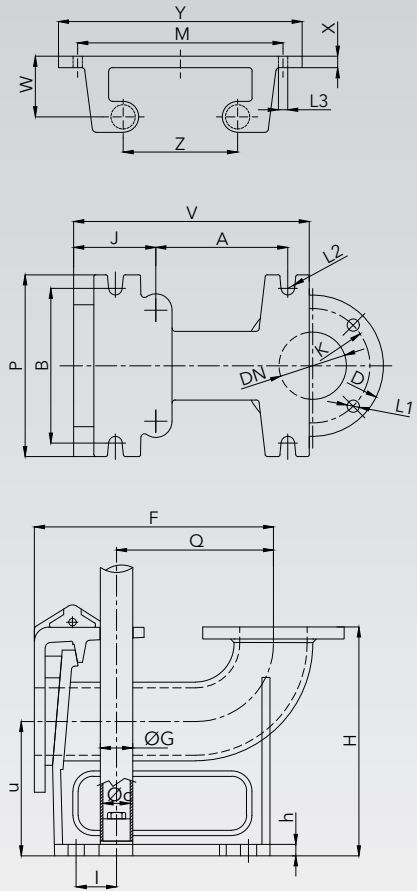

CONNECTION DIAMETER	APPLICABLE PUMP MODELS
DN65	EFP 30DP - 2P
	EFP 40DP - 2P
DN80	EFP 55DP - 2P
	EFP 30D - 2P
	EFP 40D - 2P
DN100	EFP 55D - 2P
	EFP 75DP-2P
	EFP 110DP-2P
	EFP 75D-2P
	EFP 110D-2P
	EFP 150D-2P
	EFP 55D-4P
EFP 75D-4P	
DN150	EFP 150DP-2P
	EFP 185D-2P
	EFP 110D-4P
	EFP 150D-4P
DN200	EFP 220D-4P

HUMIDITY SENSOR

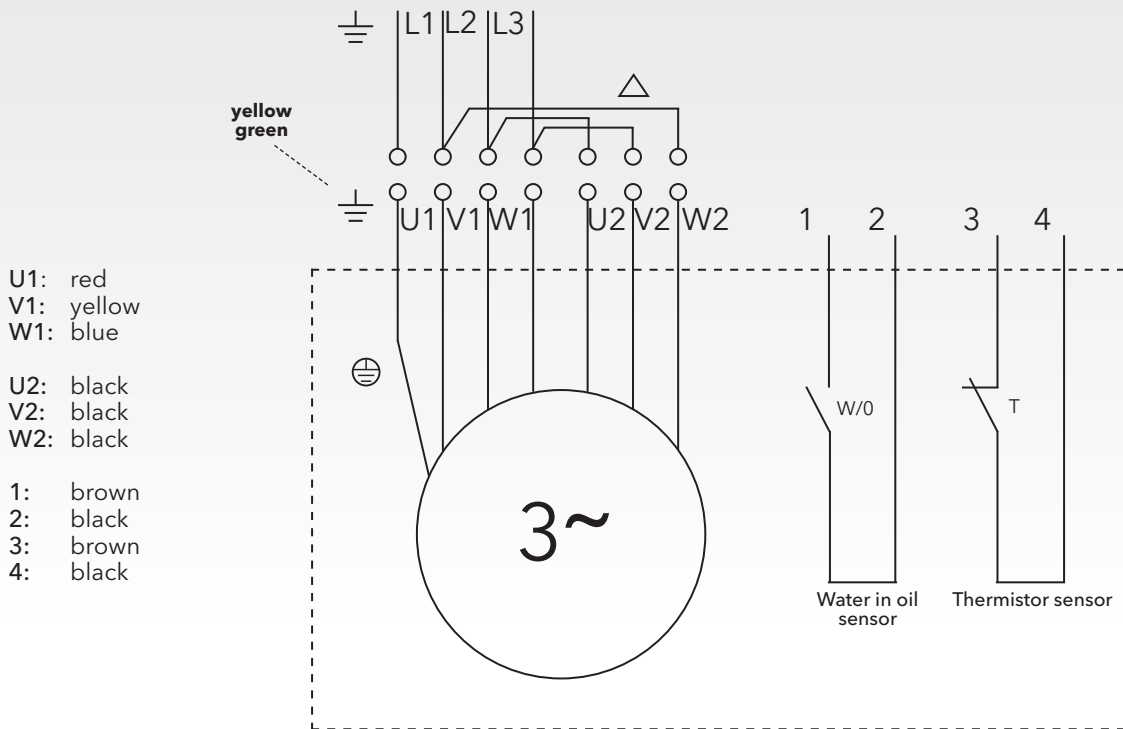
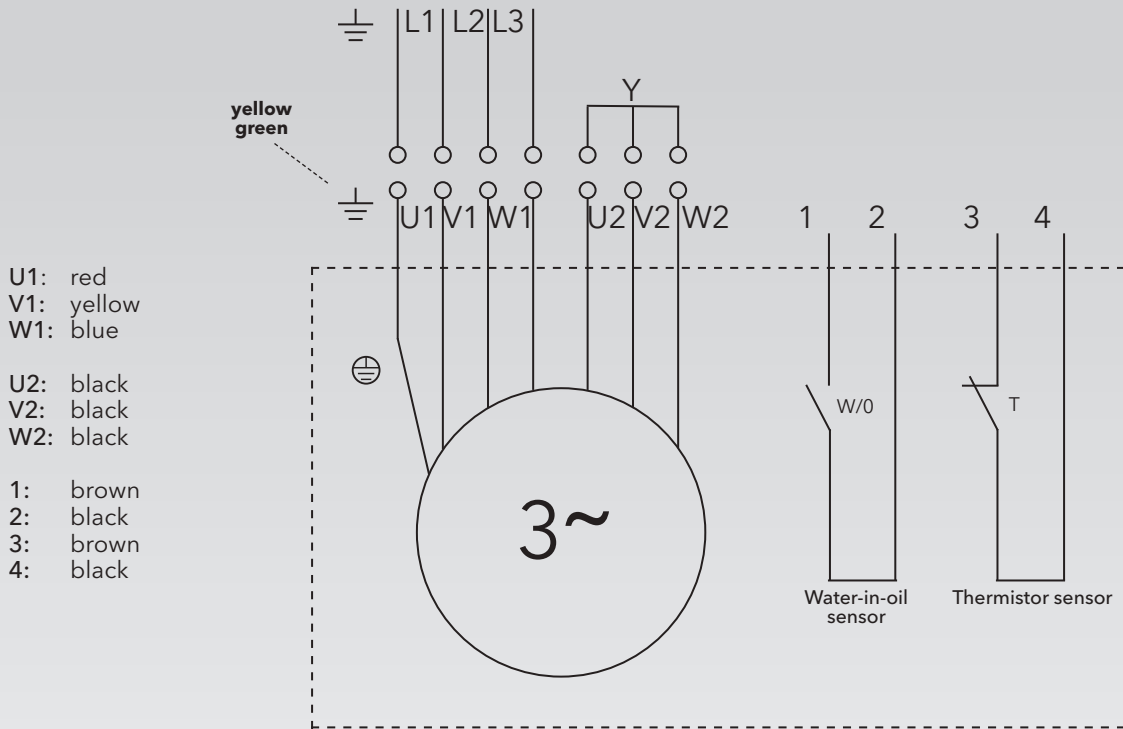

Guide rail stabilizer

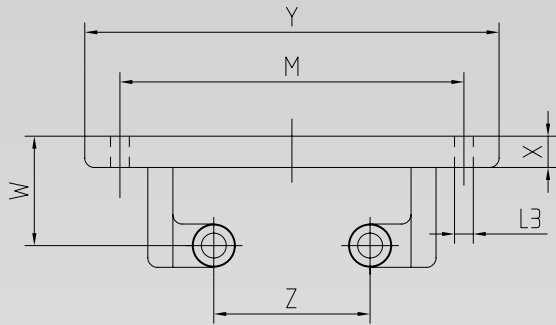

SIZE	M	Z	L3	W	X	Z
DN	mm	mm	mm	mm	mm	mm
50	216	103	2- ϕ 13	655	17	264
65	234	126	2- ϕ 13	70	17	278
80	266	146	2- ϕ 13	78	17	318
100	308	169	2- ϕ 14	73	20	368
150	250	280	2- ϕ 13	82	20	388
200	250	280	2- ϕ 14	82	20	388
250	250	280	2- ϕ 14	82	20	388
300	305	339	3- ϕ 15	111	23	480
350	318	359	3- ϕ 15	113	25	500
400	318	374	3- ϕ 15	113	25	522
500	658	460	3- ϕ 20	116	26	748
600	740	560	3- ϕ 20	112	30	830

Automatic coupling set

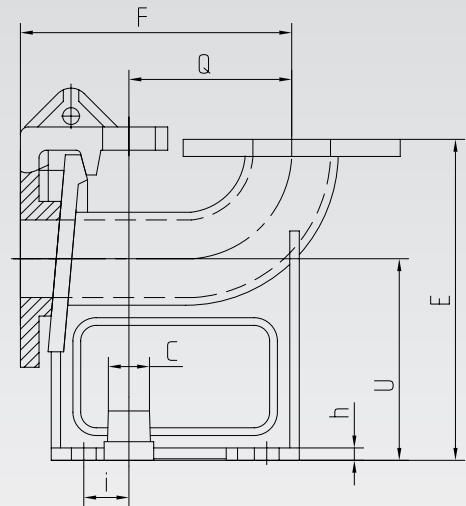
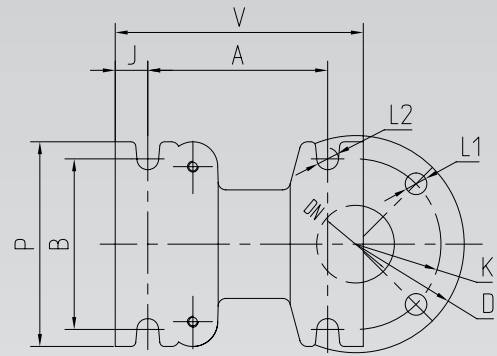

AUTOMATIC COUPLING SET	SIZE	D	K	L1	n	A	B	C	Y	F	U	Q	V	P	J	i	h	L2
	DN	mm	mm	mm	Number of holes	mm	mm	mm	mm	mm	mm	mm	mm	mm	mm	mm	mm	mm
PN6	50	140	110	14	4	133	161	25	253	218	160	132	210	197	35	13	15	20
	65	160	130	14	4	154	187	25	267	245	168	162	233	228	40	17	15	19
	80	190	150	18	4	154	214	38	306	260	185	153	224	254	35	32	15	20
	100	210	170	18	4	175	262	42	348	298	225	193	262	292	40	36	20	20
	150	265	225	18	8	300	285	42	485	480	300	291	405	360	51	90	25	22
	200	320	280	18	8	350	302	42	550	522	324	328	452	400	48	100	25	25
	250	375	335	18	12	430	360	42	632	610	308	394	560	460	61	106	25	26
PN10	200	340	295	22	8	350	302	42	550	522	324	328	452	400	48	100	25	25
	250	395	350	22	12	430	360	42	632	610	308	394	560	460	61	106	25	26
	300	445	400	22	12	410	410	50	738	617	397	394	570	550	74	64	30	26
	350	505	460	22	16	402	420	50	858	666	488	433	615	580	102	48	33	26
	400	565	515	26	16	510	490	50	958	750	562	460	680	627	85	72	33	24
	500	670	620	26	20	550	570	68.5	1158	817	652	564	752	732	100	73	33	28
	600	780	725	30	20	700	720	68	1320	935	710	660	850	830	75	109	38	33

CONCRETE SEWAGE WELL AND SEWAGE & DRAINAGE PUMP WITH LIFTING RAIL - INSTALLATION DETAILS

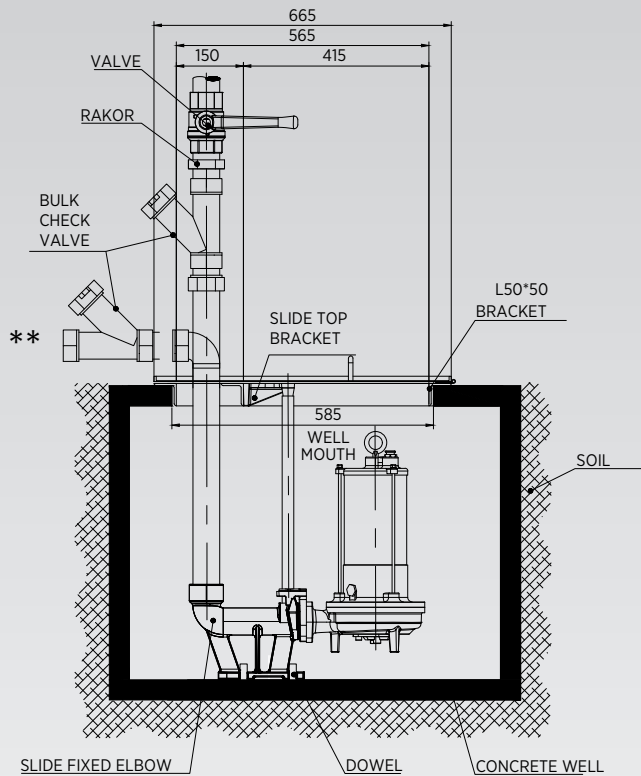

NOTE: Concrete well can be in the desired size. However, the well top should be 620x585 so that the supplied well cover with lifting rail can be mounted. Cover frame is fitted over the well top and anchored from inside.

** Alternative connection

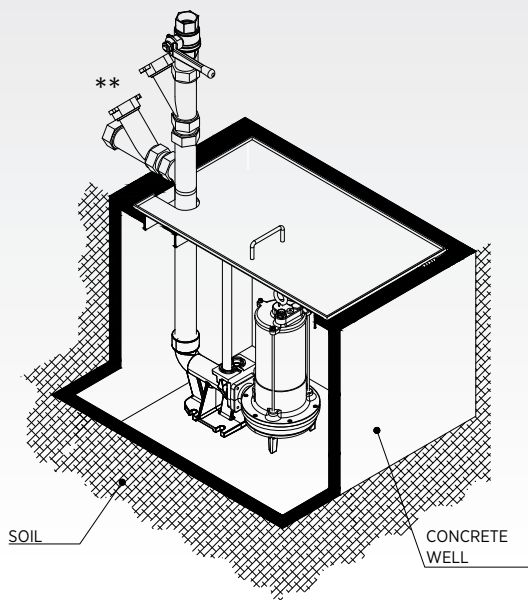

SEWAGE PUMP INSTALLATION AND WELL DETAILS



Applicable models: High-flow-rate sewage pumps rated 3KW and above (EFP D-DP Series)

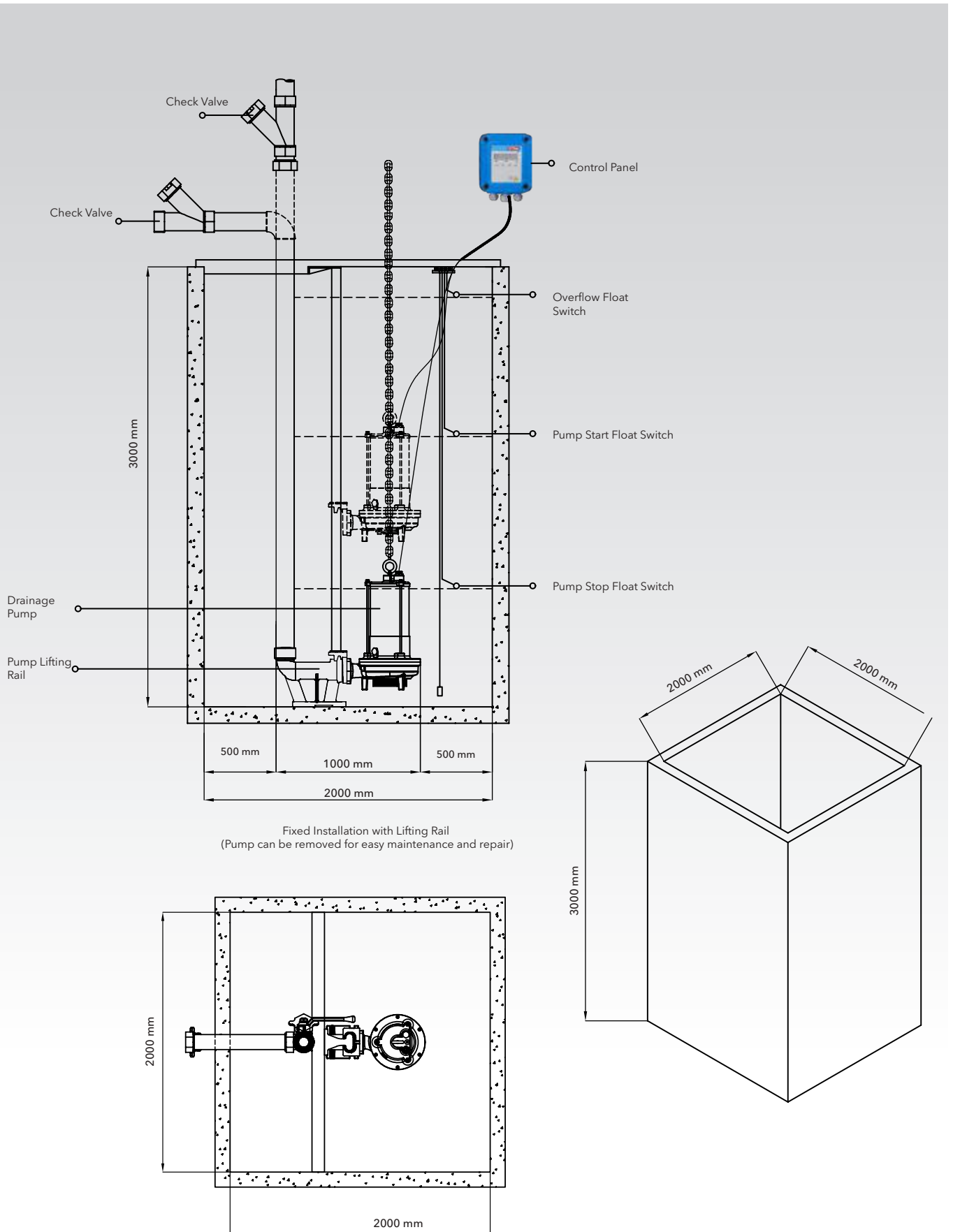

Fixed Installation with Lifting Rail
(Pump can be removed for easy maintenance and repair)



Control Panel for Deep Well and Sewage Pumps - Single Pump Systems

MODEL	POWER RANGE kW	VOLTAGE V	MAINS VOLTAGE
HYDROPAN2S	0.37-2.2	230VAC / 50 - +10%	Single-phase
HYDROPAN4S	0.37-7.5	400VAC / 50 - +10%	Three-phase

PANEL SPECIFICATIONS

- Operation with 230VAC / 50 - +10% mains voltage for single-phase model
- Operation with 400VAC / 50 - +10% mains voltage for three-phase model
- Displays phase-neutral voltages on the main operation screen in order
- Displays the current absorbed by the pump on the main operation screen
- Float switch for protection against dry running
- Adjustable low current protection for added protection against dry running.
- Adjustable high current protection
- Adjustable undervoltage protection
- Adjustable overvoltage protection
- Adjustable error delay time
- Operation mode options (Water Booster and Deep Well)
- Phase error detection and screen display
- Current error detection and screen display
- Dry running error display on screen
- IP55 insulation class
- Normal operation and dry contact error signal



Control Panel for Deep Well and Drainage Pumps - Double Pump Systems

MODEL	POWER RANGE kW	VOLTAGE V	MAINS VOLTAGE
HYDROPAN2D	0.37-2.2	230VAC / 50 - +10%	Single-phase
HYDROPAN4D	0.37-7.5	400VAC / 50 - +10%	Three-phase

NOTE: Contact us for Hydropan versions that can provide dry contact output for monitoring the pump status via the building automation system.

PANEL SPECIFICATIONS

- Operation with 230VAC / 50 - +10% mains voltage for single-phase model
- Operation with 400VAC / 50 - +10% mains voltage for three-phase model
- 8-bit microprocessor-based design
- Operating frequency: 16Mhz
- 2x16 character white LCD display
- Date and time information on main operation screen
- Three-phase voltage measurement and screen display
- Overvoltage protection setting
- Undervoltage protection setting
- Pump operation mode and error display
- Displays pump operating current during operation
- Adjustable low & high protection time
- Adjustable low & high protection values
- Error resetting
- Automatic and manual operation modes
- Manual operation with the help of test buttons
- Protection against dry running with a float switch
- Extra protection against dry running with the adjustable low current protection
- Displays all errors on the screen
- Audio error warning
- Displays pump operating time on screen
- Alternating use with sequential operation
- Password protection against unauthorized access
- Error history up to 24 errors including date and time of the error
- IP 55 insulation class
- Turkish / English language options
- General error, solenoid relay outlet, and operation/dry contact PTC protection inlets are available in the higher versions
- Adjustable low & high protection values



PRODUCT
Check Valve 1" 1/4
Check Valve 1" 1/2
Check Valve 2"
Check Valve 2"1/2
Check Valve with Flange - DN50
Check Valve with Flange - DN65
Check Valve with Flange - DN80
Check Valve with Flange - DN100
Check Valve with Flange - DN65

Rev. 10/2024



Dudullu Organize Sanayi Bölgesi 2. Cadde No: 14
34775 Ümraniye İstanbul / Turkey
Tel : +90 216 561 47 74 (Pbx) • Fax : +90 216 561 47 50
www.etna.com.tr/en • info@etna.com.tr



ETNA®

0850 455 38 62
customer service